

PARTS LIST

DLR SERIES

Industrial Sewing Machines

DLR-1502P

DLR-1501P-HD

DLR-1502P-HD

DLR-1502PMD

DLR-1503P

DLR-1503P-TF

DLR-1503P-HD

DLR-1504P

DLR-1504PMD

DLR-1507P

DLR-1508P

DLR-1508PR

DLR-1508PD

Industrial Sewing Machines

Kansai Special

Contents

1. Housing components (カバー機構)	1
2. Thread eyelet components (糸道機構)	3
3. Bushings (ブッシュ機構)	5
4. Oil lubrication apparatus (給油機構)	7
5. Needle lever crank (弓・クランク機構)	9
6. Feed rocker (送り台機構)	11
7. Looper (ルーパー台機構)	13
8. Foot lifter mechanism (押え揚げ機構)	15
9. Puller (プーラー機構)	17
10. Gauge parts (1) ゲージ関係(1)	19
11. Gauge parts (2) ゲージ関係(2)	20
12. Gauge parts (3) ゲージ関係(3)	21
13. DLR-P Series gauge parts index (DLR-Pシリーズパーツ一覧表)	22
Subclass models (サブクラス機種)	
14. 1502PMD-1504PMD Front puller mechanism (前プーラー装置)	23
15. 1501P-HD-1502P-HD	25
16. 1503P-TF-1503P-HD	27
17. 1504P	29
18. 1507P	31
19. Part for 1508P-PR-PD共通	33
20. 1508P-PR-PD	37
21. 1508PD	39
22. 1508PD	41
23. Thread stand (糸立て)	43
24. Attachment-Accessories (アタッチメント・アクセサリ)	45
25. Table stand assembly diagram (テーブルスタンド据付図)	47
26. Table diagram (テーブル図) Standard Type	48
27. Index (索引)	49

1. Housing components (カバー機構)

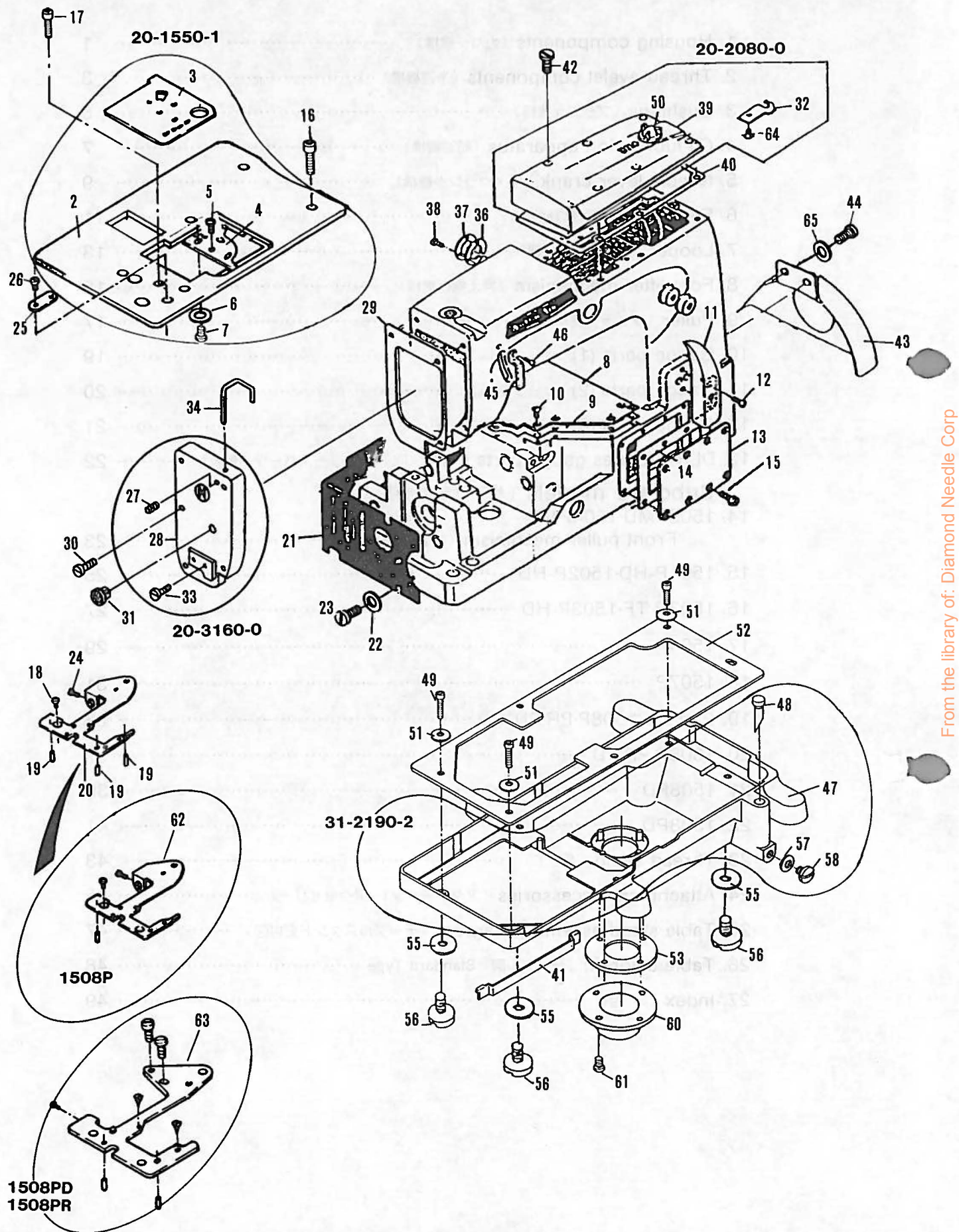

No.	Part No.	Part Name	品名	Q, ty
2	21-5510-0	Upper cloth plate C	上ベースカバーC	1
3	21-5220-0	Side plate B	差し板	1
4	21-5310-0	Spring A	差し板用板バネA	1
5	85-6110-0	Screw	ネジ	1
6	75-4540-0	Washer	ワッシャ	3
7	84-5850-0	Screw	ネジ	3
8	21-5190-0	Oil reservoir top cover	上油カバー	1
9	23-2290-0	Oil reservoir top cover gasket	上油カバーパッキン	1
10	84-6610-0	Screw	ネジ	8
11	21-1350-0	Tension post cover	チャンポン皿カバー	1
12	84-3610-0	Screw	ネジ	1
13	21-1220-0	Oil reservoir front cover	前油カバー	1
14	23-2340-0	Oil reservoir front cover gasket	前油カバーパッキン	1
15	84-6640-0	Screw	ネジ	8
16	84-8610-0	Screw	ネジ	2
17	84-8620-0	Screw	ネジ	3
18	84-7610-0	Screw	ネジ	3
19	71-2510-0	Knock pin	ノックピン	4
20	14-0920-2	Needle plate support C	針板土台C	1
21	21-3660-0	Cover	横板カバーB	1
22	75-4670-0	Washer	ワッシャ	3
23	84-6110-0	Screw	ネジ	3
24	84-1640-0	Screw	ネジ	1
25	26-7120-0	Folder mounting bracket	ラッパ取付台	1
26	85-1810-0	Screw	ネジ	2
27	84-5210-0	Screw	ネジ	1
28	21-3160-0	Head cover	面板	1
29	23-2160-0	Head cover gasket	面板パッキン	1
30	84-5660-0	Screw	ネジ	5
31	23-1610-0	Head cover oil seal cover	面板油止め蓋	1
32	39-1370-0	Pipe support	配管B用サポート	1
33	84-5710-0	Screw	ネジ	2
34	21-7010-0	Needle bar eyelet safety bar A	針棒系保護カバーA	1
36	23-2630-0	Oil seal plate gasket	弓ピン油止めパッキン	1
37	39-1080-0	Oil seal plate B	弓ピン油止め板B	1
38	84-3620-0	Screw	ネジ	3
39	21-2080-0	Crank chamber oil cover	立ロットカバー	1
40	23-2060-0	Crank chamber oil cover gasket	立ロットカバーパッキン	1
41	39-1670-0	Oil fence	オイルタンク用フェンスB	1
42	84-5660-0	Screw	ネジ	6
43	21-4020-0	Pulley cover	プーリーカバー	1
44	84-5710-0	Screw	ネジ	2
45	21-7110-0	Needle lever eyelet safety plate	弓糸道保護バーA	1
46	84-5710-0	Screw	ネジ	1
47	31-2190-2	Oil tank	オイルタンク	1
48	39-2160-0	Oil gauge E	オイルゲージ E	1
49	85-6280-0	Screw	ネジ	2
50	39-2330-0	Oil pot lid	オイルポット	1
51	75-4520-0	Washer	ワッシャ	2
52	23-1590-0	Packing	オイルタンクパッキン	1
53	23-9130-0	Oil filter Packing	オイルフィルター受	1
55	23-1200-0	Oil tank packing	オイルタンクパッキン	4
56	85-2200-0	Screw	ネジ	4
57	23-3040-0	Drain seal	オイルタンクドレンシール	1
58	87-3110-0	Screw	ネジ	1
60	35-9150-0	Oil filter plate	オイルフィルター受	1
61	84-7630-0	Screw	ネジ	4
62	14-0910-2	Needle plate support	針板土台	1
63	14-0580-2	Needle plate support	針板土台	1
64	84-1610-0	Screw	ネジ	1
65	75-4550-0	Washer	ワッシャ	2

2. Thread eyelet components (糸道機構)

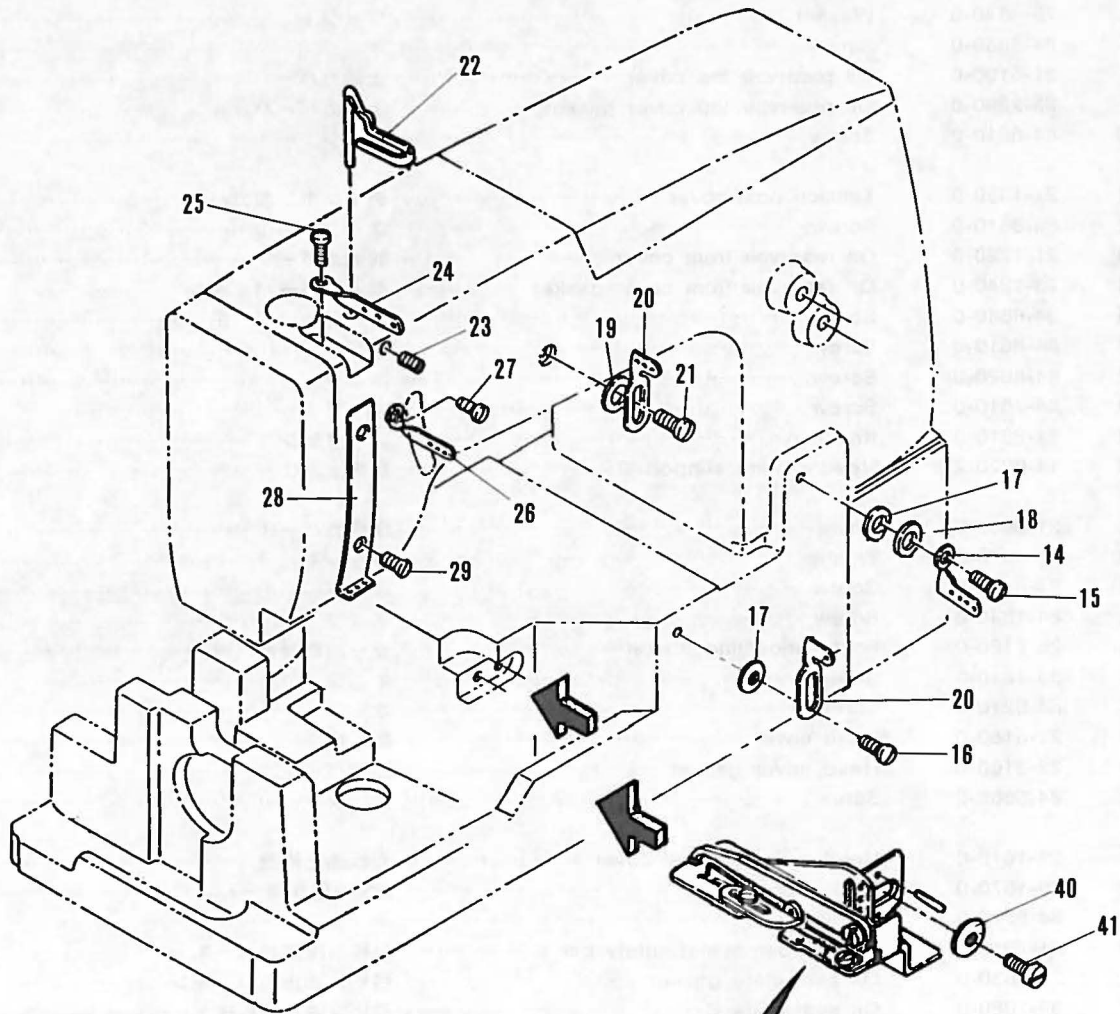

40-122B-0

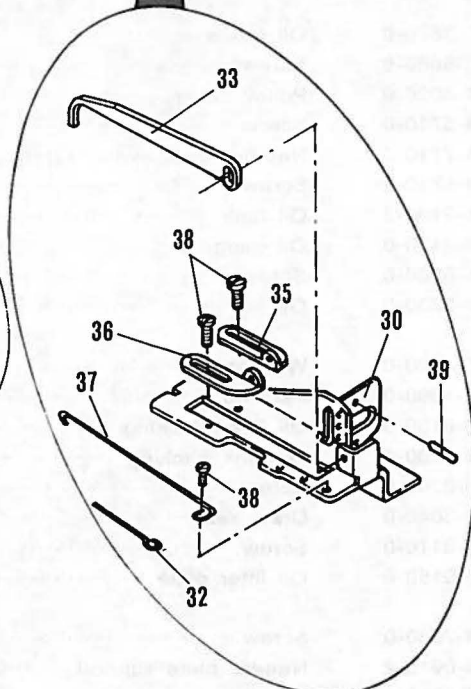
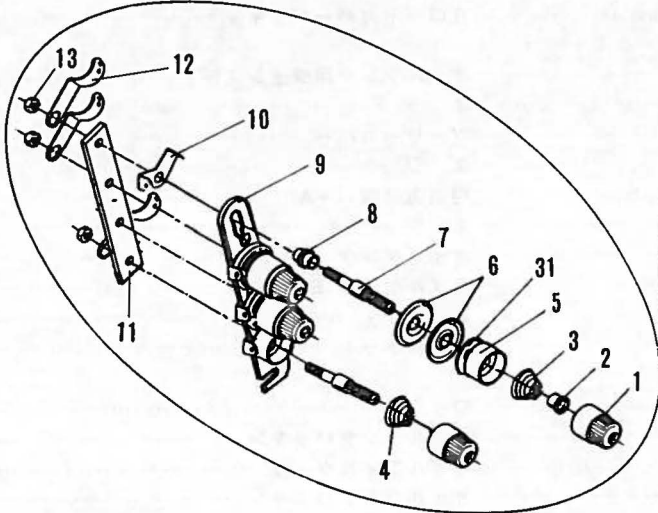

40-3820-0

No.	Part No.	Part Name	品 名	Q, ty
1	41-1010-0	Tension regulating nut	チャンボン皿小ケース	4
2	41-1050-0	Tension disc ratchet	チャンボン皿ラチェット	4
3	41-7010-0	Needle thread tension spring	チャンボン調子バネ強	2
4	41-7020-0	Looper thread tension spring	チャンボン調子バネ弱	2
5	41-1070-0	Tension disc cover	チャンボン皿大ケース	4
6	41-1110-0	Tension disc	チャンボン皿	8
7	41-1720-0	Tension post	調子棒 中	4
8	41-1310-0	Tension post collar A	調子棒カラーA	4
9	41-113B-0	Tension post support	チャンボン調節板	1
10	41-1150-0	Tension post thread eyelet	糸道上	4
11	41-121B-0	Tension post holder	チャンボン調節元板	1
12	41-1170-0	Lead in thread eyelet	糸道下	4
13	86-4110-0	Nut	ナット	2
14	45-1020-0	Needle thread eyelet (upper)	上糸糸道	1
15	84-5660-0	Screw	ネ ジ	1
16	84-3610-0	Screw	ネ ジ	2
17	23-1870-0	O-ring	Oリング	2
18	75-4550-0	Washer	ワッシャ	1
19	75-4560-0	Washer	ワッシャ	1
20	45-1010-0	Needle thread eyelet 2	下糸糸道2	2
21	84-5710-0	Screw	ネ ジ	1
22	45-2250-0	Needle thread take-up wire E	角形上糸受けE	1
23	84-5210-0	Screw	ネ ジ	1
24	45-1310-0	Needle bar thread eyelet	針棒糸道	1
25	84-3610-0	Screw	ネ ジ	1
26	45-1210-0	Needle lever thread eyelet	弓糸道 B2	1
27	84-3610-0	Screw	ネ ジ	1
28	45-1620-0	Needle thread guide	上糸ガイド	1
29	84-4640-0	Screw	ネ ジ	2
30	43-3310-0	Cast-off support bracket	下糸捌き上取付台	1
31	23-3240-0	Felt	フェルト	4
32	43-1050-0	Pin	下糸捌きピン	1
33	43-3440-0	Retainer upper	下糸捌き上	1
34	84-3740-0	Screw	ネ ジ	1
35	47-1310-0	Looper thread guide eyelet (right)	下糸捌き板案内糸道右	1
36	47-1320-0	Looper thread guide eyelet (left)	下糸捌き板案内糸道左	1
37	43-3350-0	Looper thread retainer wire	下糸捌き下ピンB	1
38	84-1610-0	Screw	ネ ジ	4
39	71-1910-0	Pin	下糸捌きノックピン	2
40	75-4560-0	Washer	ワッシャ	1
41	84-5710-0	Screw	ネ ジ	1

3. Bushings (ブッシュ機構)

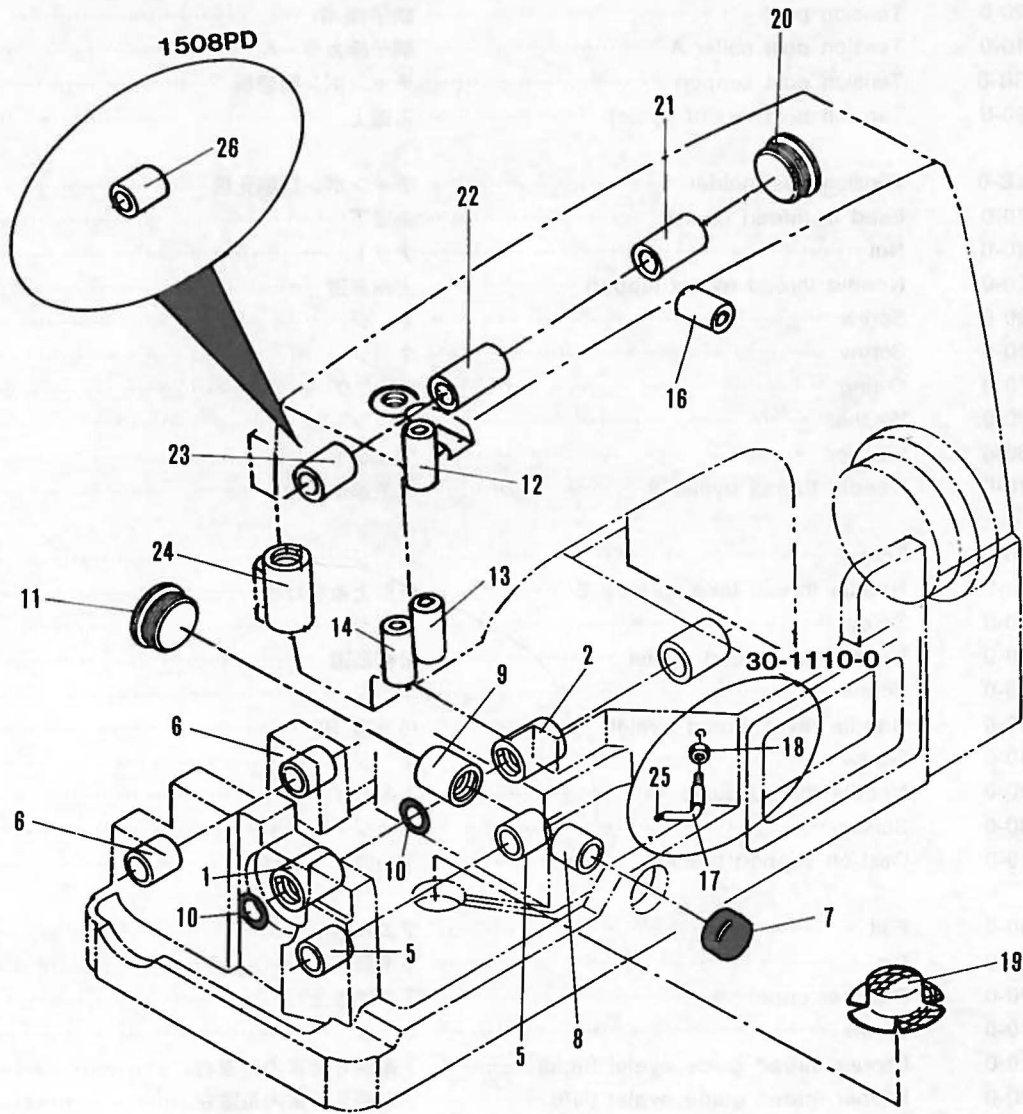

No.	Part No.	Part Name	品名	Q, ty
1	81-7140-0	Main shaft bushing A	下シャフトブッシュ前	1
2	81-7200-0	Main shaft bushing B	下シャフトブッシュ中	1
3	81-8070-0	Main shaft bushing C	下シャフトブッシュ後	1
5	81-7350-0	Looper rocker shaft bushing	ルーバー台シャフトブッシュ左B	2
6	81-7530-0	Feed rocker bushing	送り台シャフトブッシュB	2
7	23-1660-0	Rubber plug	ブッシュ蓋ゴムA	1
8	81-2360-0	Looper drive shaft bushing B	ルーバー振り元シャフトブッシュB大	1
9	81-2370-0	Looper drive shaft bushing C	ルーバー振り元シャフトブッシュC大	1
10	94-2140-0	Oil seal	オイルシール	2
11	23-2960-0	Oil cap	ブッシュ油止め	1
12	81-1830-0	Needle bar bushing	針棒ブッシュC上	1
13	81-1840-0	Needle bar bushing	針棒ブッシュC下	1
14	81-1530-0	Presser bar bushing	押え棒ブッシュ大	1
16	81-2550-0	Presser foot lifter bushing	押え揚げ土台ブッシュC	1
17	35-1110-0	Feed rocker eccentric link tubing	送り台配管	1
18	86-5010-0	Nut	ナット	1
19	31-4380-0	Bed filter	ベットフィルター	1
20	23-2960-0	Oil cap	ブッシュ油止め	1
21	81-1140-0	Puller drive lever bushing	上シャフトブッシュ	1
22	81-1090-0	Puller drive lever bushing	上シャフトブッシュC	1
23	81-1080-0	Puller drive lever bushing	上シャフトブッシュ	1
24	81-1330-0	Puller shaft bushing	押え棒ブッシュ	1
25	23-3410-0	Felt	フェルト	1
26	98-1230-0	Bushing	ブッシュ	1

4. Oil lubrication apparatus (給油機構)

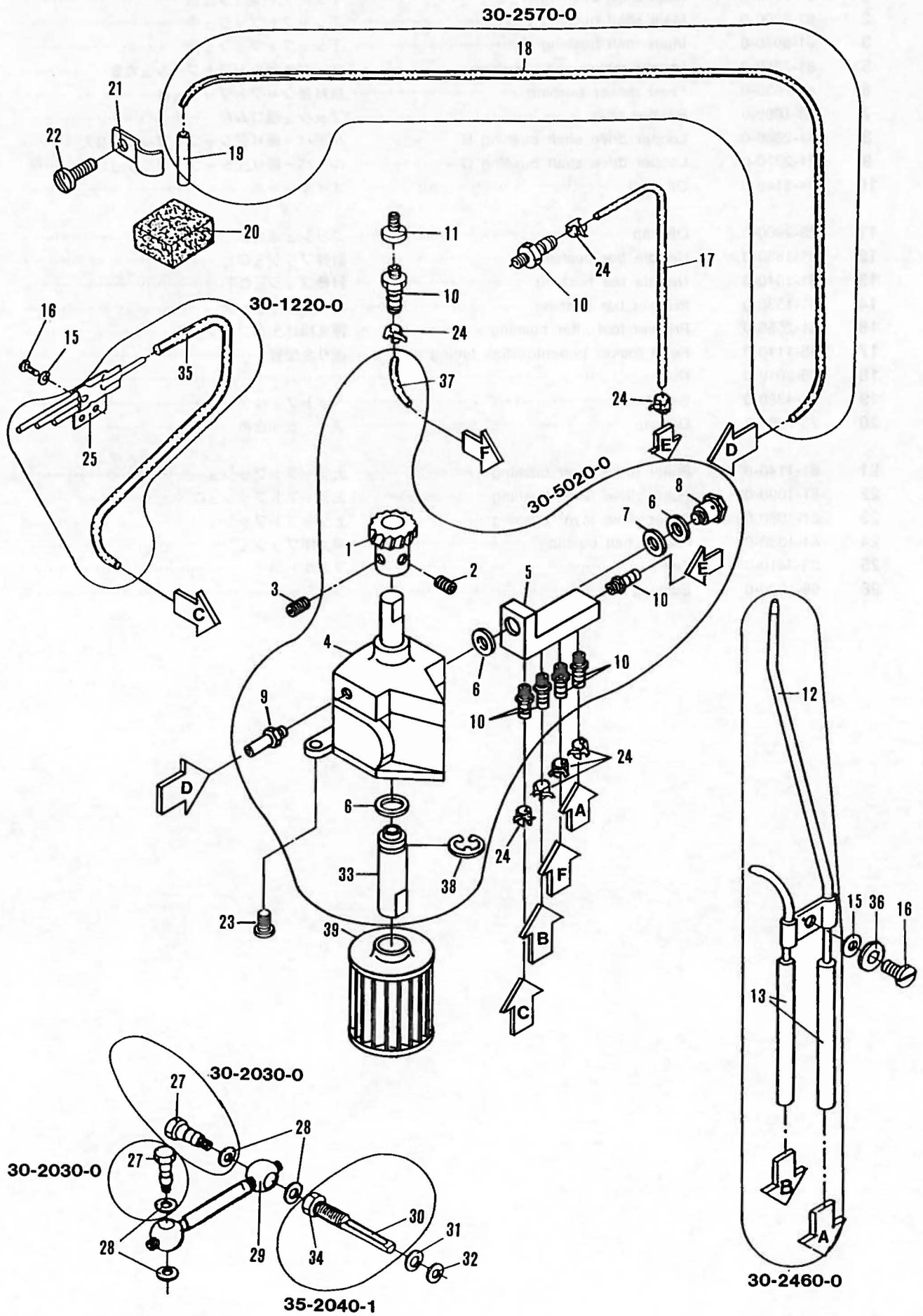

From the library of: Diamond Needle Corp

No.	Part No.	Part name	品 名	Q, ty
1	31-4090-0	Gear	ポンプウォーム歯車	1
2	84-5210-0	Screw	ネジ	1
3	84-5110-0	Screw	針止メネジ	1
4	30-0150-0	Pump set	ポンプセット	1
5	31-2490-0	Oil separator	オイルセパレーター	1
6	75-4700-0	Washer	ドレンワッシャB	3
7	23-1640-0	Pomp tubu joint seal	ポンプチューブジョイントシール	1
8	35-8220-0	Screw	ポンプ配管ネジ	1
9	31-3640-0	Pipe joint	ビニールパイプ継手	1
10	31-3140-0	Pipe joint	ビニールパイプ継手C	7
11	85-5310-0	Screw	ネジ	1
12	35-2460-0	Piping	立ロット用セット配管	1
13	35-3170-0	Tube (290L)	ビニールチューブ290L	2
15	23-1600-0	Packing	配管油止めシール	3
16	84-3630-0	Screw	ネジ	3
17	35-3180-0	Tube (440L)	シリコン糸道用ビニールパイプ	1
18	35-3220-0	Tube (600L)	ビニールパイプ小B	1
19	35-2570-0	Pipe	面板オイルバックパイプA	1
20	23-3630-0	Felt	面板用フェルトD	1
21	39-1330-0	Support	パイプサポートC	1
22	84-3610-0	Screw	ネジ	1
23	84-5660-0	Screw	ネジ	2
24	35-4120-0	Pipe clamp	配管チューブ止め金具小	7
25	35-1220-0	Pipe	セパレート配管B	1
27	35-2030-0	Screw	ネジ	2
28	23-9110-0	Packing	配管油止めシール	4
29	30-5000-0	Tube coupling	送り台配管用チューブジョイント	1
30	35-2040-0	Screw	オイルフォローネジ	1
31	75-4700-0	Washer	ワッシャB	1
32	23-1640-0	Gasket	ポンプチューブジョイントシール	1
33	35-1070-0	Filter tube	フィルター用吸口	1
34	86-7610-0	Nut	ナット	1
35	35-3150-0	Vinyl pipe (190L)	ビニールチューブ190L	1
36	75-4550-0	Washer	ワッシャ	1
37	35-3430-0	Pipe	パイプ	1
38	93-2230-0	E-ring	Eリング	1
39	31-2220-0	Oil filter	オイルフィルター	1

5. Needle lever crank (弓・クランク機構)

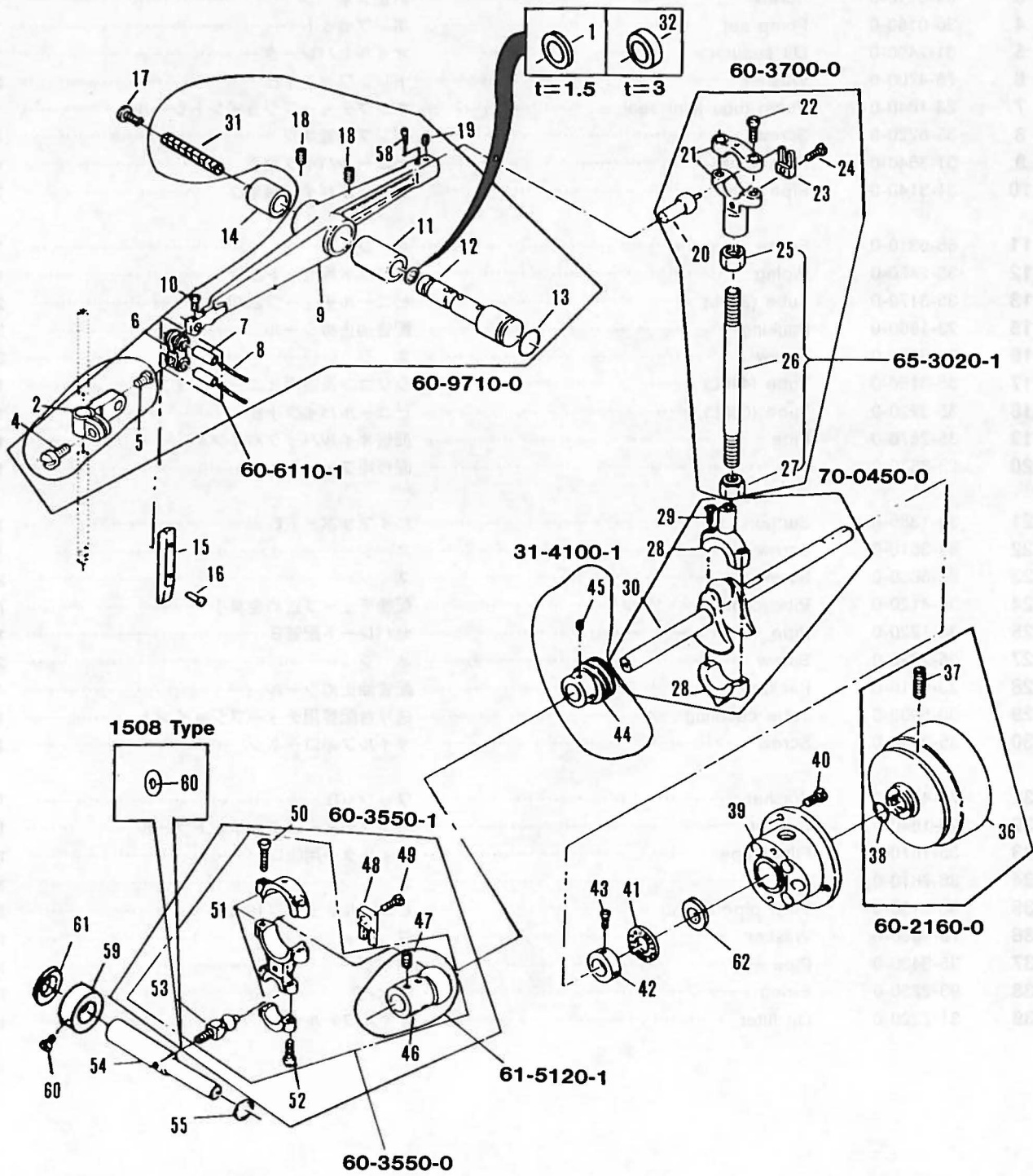

No.	Part No.	Part Name	品名	Q, ty
1	75-3320-0	Washer	ワッシャ t=1.5	1
2	73-1130-1	Needle bar clamp	針棒クランプ	1
4	84-5640-0	Screw	ネジ	1
5	84-3650-0	Screw	ネジ	1
6	66-1110-0	Needle bar connecting link	連結メガネ	1
7	71-4320-0	Needle bar connecting link pin	メガネピン	2
8	23-3410-0	Felt	メガネピン用フェルト	2
9	69-1050-2	Needle lever E	弓E	1
10	84-3660-0	Screw	ネジ	1
11	81-1130-0	Needle lever bushing	弓ブッシュ	1
12	71-9330-0	Needle lever stud	角型弓ピンC	1
13	23-1950-0	O-ring	弓ピン油止め用Oリング	1
14	81-4120-0	Needle lever stud bushing	弓ピンブッシュB	1
15	69-1170-0	Needle bar guide plate	針棒案内板	1
16	84-5740-0	Screw	ネジ	2
17	85-1810-0	Screw	ネジ	1
18	85-1140-0	Screw	ネジ	2
19	85-1130-0	Screw	ネジ	1
20	61-7110-U	Needle lever connecting rod ball	立ロッド玉	1
21	63-7130-1	Ball joint for connecting rod	立ロッド小	1
22	84-5670-0	Screw	ネジ	2
23	69-1210-0	Eccentric guide fork	ロッド振れ止め	1
24	84-5720-0	Screw	ネジ	1
25	86-7420-0	Nut	ナット	1
26	65-3020-0	Connecting bar	上シャフト連結棒	1
27	86-7410-0	Nut	ナット	1
28	63-6210-1	Crank shaft ball joint	立ロッド大	1
29	84-5680-0	Screw	ネジ	2
30	71-8580-0	Crank shaft 5LB	クランクシャフト5LB	1
31	23-3960-0	Felt	フェルト	1
32	75-3310-0	Washer	ワッシャ t=3	1
36	69-2160-0	Pulley	プーリーJ	1
37	85-1140-0	Screw	ネジ	2
38	23-1970-0	O-ring	11.5 Oリング	1
39	69-3050-2	Flange	フレンジE	1
40	84-5660-0	Screw	ネジ	3
41	92-2310-0	Bearing	13.45スラストベアリング	1
42	75-1120-1	Crank shaft collar	クランクシャフトカラー小	1
43	84-5630-0	Screw	ネジ	2
44	31-4100-0	Worm gear	ポンプウォームホイール	1
45	84-7180-0	Screw	ネジ	2
46	61-5120-U	Looper driving rod	ルーバー振り元ロッド玉	1
47	85-1130-0	Screw	ネジ	6
48	69-1210-0	Eccentric guide fork	ロッド振れ止め	1
49	84-5720-0	Screw	ネジ	1
50	84-5680-0	Screw	ネジ	2
51	63-5110-1	Looper driving lever ball joint	振り元ロッドA	1
52	84-5720-0	Screw	ネジ	2
53	61-7130-U	Looper driving connecting rod	ルーバー振り元ロッド小玉B	1
54	71-6120-0	Looper driving shaft	ルーバー振り元シャフト大	1
55	75-3320-0	Washer	ワッシャ	1
58	85-2120-0	Screw	ネジ	1
59	75-1070-1	Looper driving collar	ルーバー振り元止めカラー	1
60	85-2120-0	Screw	ネジ	1
61	75-3220-0	Washer	ワッシャ	1
62	75-3270-0	Washer	ワッシャ	1

6. Feed rocker (送り台機構)

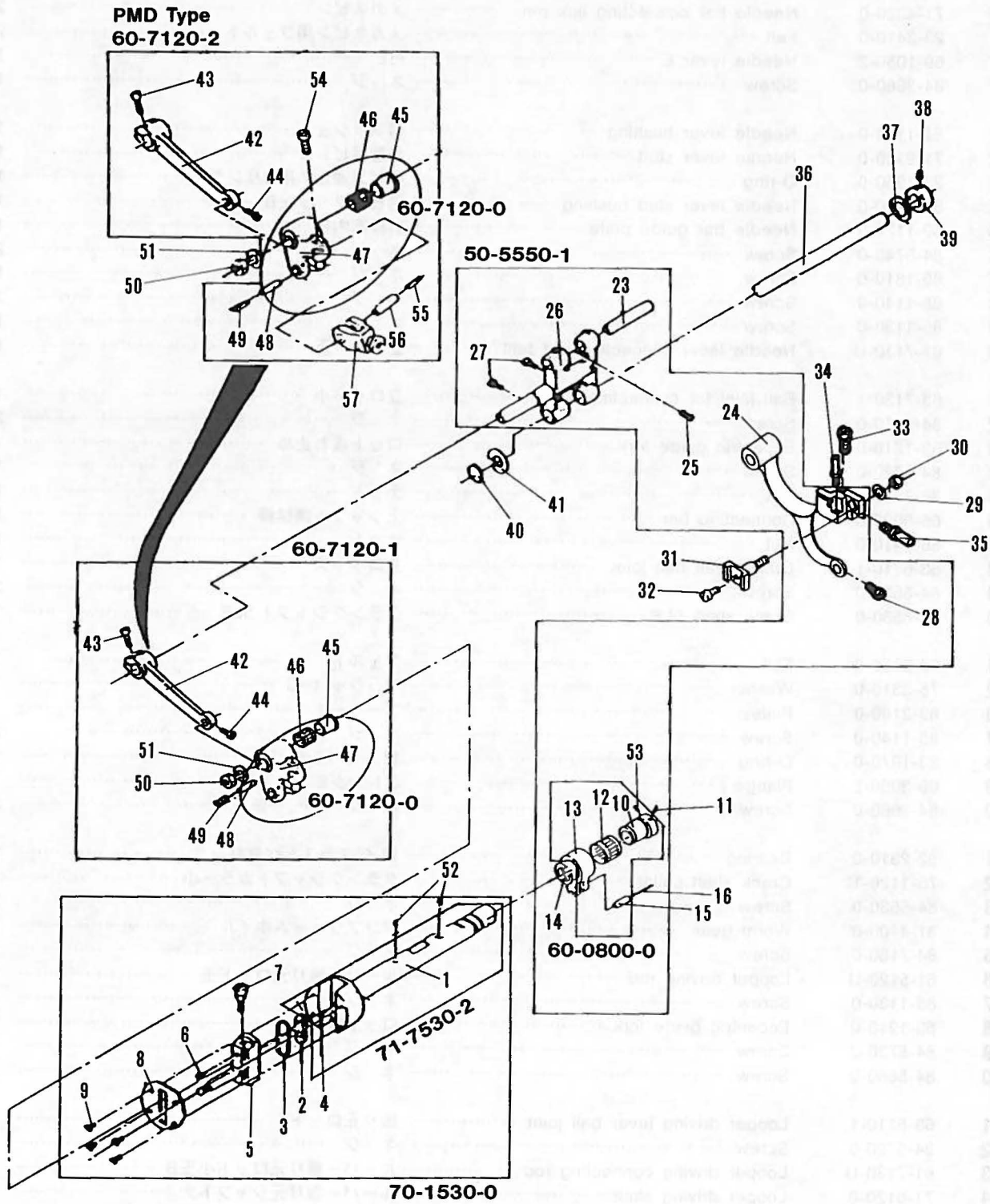

From the library of: Diamond Needle Corp

No.	Part No.	Part Name	品 名	Q, ty
1	71-7530-0	Main shaft 5C	前下シャフト 5C	1
2	51-0360-0	Oil guard	送り調節心棒オイルガード	1
3	23-1970-0	O-ring	O-リング	1
4	23-3930-0	Felt	フェルト	1
5	51-0130-0	Feed crank adjusting post	送り調節芯棒C	1
6	85-6240-0	Screw	ネ ジ	1
7	84-3830-0	Screw	ネ ジ	1
8	51-0310-0	Main shaft plate	メインシャフトプレート	1
9	84-6610-0	Screw	ネ ジ	4
10	61-3120-0	Looper avoid eccentric	針返しオキセン玉	1
11	84-5210-0	Screw	ネ ジ	1
12	91-4060-0	Bearing	エキセン用ベアリング	1
13	63-2320-U	Eccentric link	エキセンダルマ	1
14	93-4060-0	Snap ring	サークリップ	1
15	71-4310-0	Link pin	ダルマピン	1
16	23-3410-0	Felt	フェルト	1
23	71-5310-0	Feed rocker shaft (small)	後送り歯取付台シャフト	1
24	55-1550-0	Feed bar	送り土台	1
25	84-7120-0	Screw	ネ ジ	1
26	55-0410-0	Feed rocker arm	送り元台	1
27	84-5210-0	Screw	ネ ジ	2
28	84-3660-0	Screw	ネ ジ	1
29	75-3810-0	Washer	ワッシャ	1
30	86-5010-0	Nut	ナット	1
31	55-0510-0	Feed dog holder	送り歯取付台	1
32	84-5880-0	Screw	ネ ジ	1
33	84-4630-0	Screw	ネ ジ	1
34	84-1770-0	Screw	ネ ジ	1
35	84-1760-0	Screw	ネ ジ	1
36	71-6420-0	Feed rocker arm shaft	送り元台シャフト	1
37	75-3720-0	Washer	ワッシャ	1
38	84-8160-0	Screw	ネ ジ	1
39	75-1320-1	Collar	カラー	1
40	93-2610-0	Snap ring	型止め輪	1
41	75-3720-0	Washer	ワッシャ	1
42	67-3110-1	Feed rocker arm	送り連結レバー	1
43	84-6120-0	Screw	ネ ジ	2
44	84-3660-0	Screw	ネ ジ	1
45	75-2430-0	Feed crank link collar	送りダルマローラー	1
46	91-2710-0	Bearing	ベアリング	1
47	63-3530-2	Feed rocker link	送りダルマ	1
48	71-4320-0	Eccentric link pin	メガネピン	1
49	23-3410-0	Felt	フェルト	1
50	86-4120-0	Nut	ナット	1
51	75-4530-0	Washer	ワッシャ	1
52	23-3410-0	Felt	フェルト	1
53	84-5210-0	Screw	ネ ジ	1
54	84-3660-0	Screw	ネ ジ	1
55	23-3410-0	Felt	フェルト	1
56	71-4320-0	Pin	ピン	1
57	66-1310-0	Connecting link	連結メガネ	1

7. Looper (ルーパー台機構)

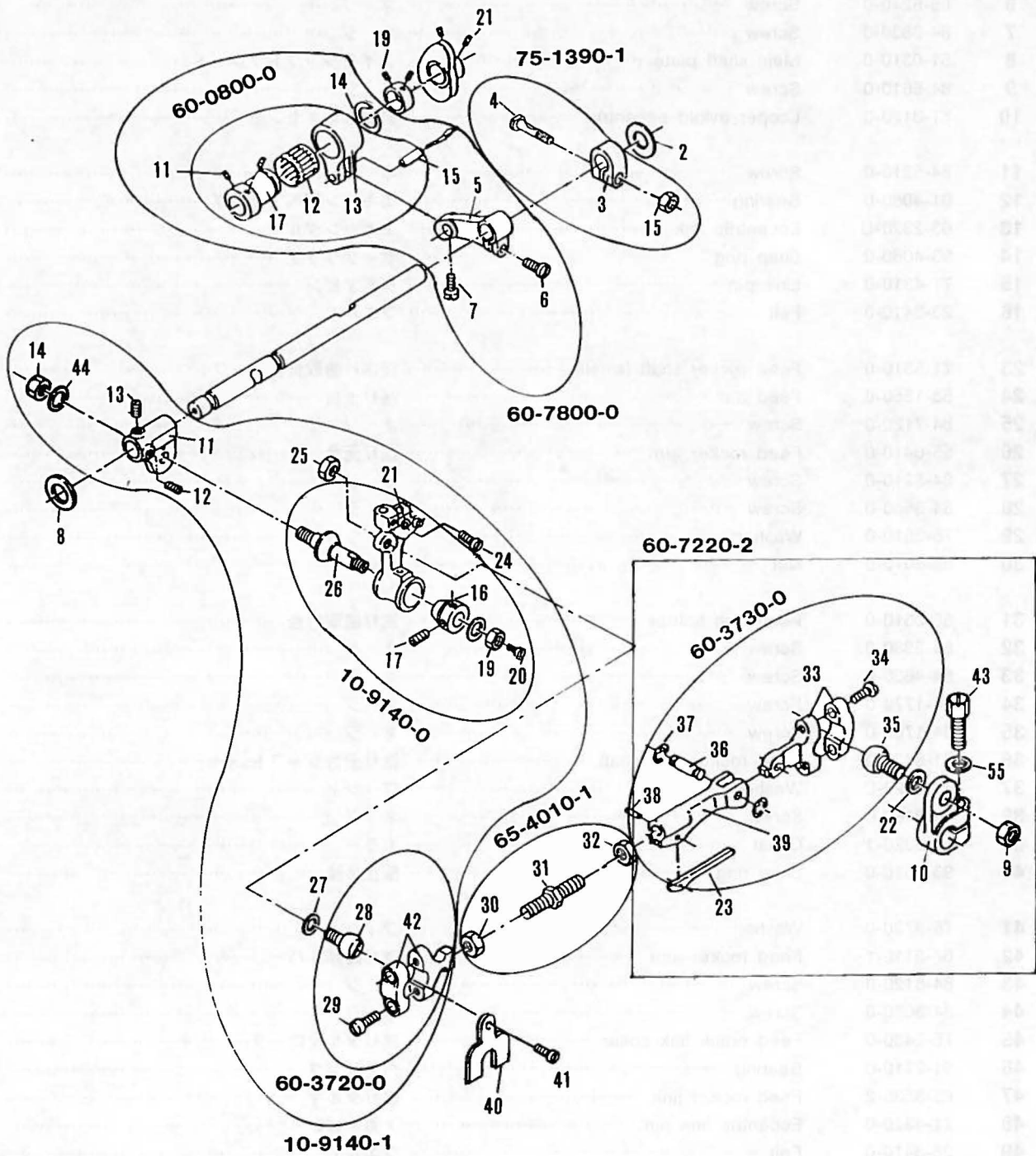

No.	Part No.	Part Name	品 名	Q, ty
1	71-5610-0	Looper holder shaft B	ルーバー台シャフトB	1
2	75-3720-0	Washer (small)	ワッシャ小	1
3	75-1390-1	Looper holder shaft coller B	ルーバー台シャフト締めカラーB	1
4	71-4540-0	Pin	締めカラー止めピン	1
5	67-1320-1	Looper avoid lever B	針返しダルマレバーB	1
6	84-6120-0	Screw	ネジ	1
7	84-3660-0	Screw	ネジ	1
8	75-3720-0	Washer (small)	ワッシャ小	1
9	86-4110-0	Nut (right)	ナット右	1
10	67-2220-1	Looper driving iever B	ルーバー振り元レバーB	1
11	19-3050-0	Looper rocker E	ルーバー元台E	1
12	84-7670-0	Screw	ネジ	1
13	84-7660-0	Screw	ネジ	1
14	86-5020-0	Nut	ナット	1
15	86-3140-0	Nut	ナット	1
16	81-4010-1	Tapered pin bushing	テーバピン押しブッシュ	1
17	84-5210-0	Screw	ネジ	2
18	75-4520-0	Washer	ワッシャ	1
19	86-5010-0	Nut	ナット	1
20	84-3610-0	Screw	ネジ	1
21	19-3140-0	Looper holder D	ルーバー台D	1
22	75-4010-0	Washer	ワッシャ	1
23	79-6010-0	Spring	折曲げロッド用板バネ	1
24	84-6160-0	Screw	ネジ	1
25	86-4130-0	Nut (right)	ナット右	1
26	71-9010-0	Looper rocker tapered pin	ルーバー台テーバピン	1
27	75-4530-0	Washer	ワッシャ	1
28	61-8230-U	Connecting ball (left)	ルーバー連結ロッド玉左	1
29	84-6350-0	Screw	ネジ	2
30	86-4120-0	Nut (left)	ナット左	1
31	65-4010-0	Connecting bar (large)	連結棒大	1
32	86-4110-0	Nut (right)	ナット右	1
33	63-8210-U	Looper driving connecting ball joint	ルーバー折曲げロッド	1
34	84-5720-0	Screw	ネジ	2
35	61-8230-U	Connecting ball (left)	ルーバー連結ロッド玉左	1
36	71-3220-0	Pin	折曲げダルマピン	1
37	93-2010-0	Snap ring	ルーバー振り元レバーE	2
38	71-2010-0	Pin	ノックピン	1
39	65-9020-0	Looper driving connecting link	折曲げダルマ連結金具	1
40	35-1990-0	Oil guide	ルーバー台用オイル案内板	1
41	84-1640-0	Screw	ネジ	1
42	63-8120-0	Connecting rod (left)	連結ロッド左	1
43	85-2100-0	Screw	ネジ	1
44	75-3810-0	Screw	ネジ	1
45	91-4060-0	Bearing	エキセン用ベアリング	1
46	63-2320-0	Eccentric link	エキセンダルマ	1
47	93-4060-U	Snap ring	サークリップ	1
48	71-4310-0	Link pin	ダルマピン	1
49	23-3410-0	Felt	フェルト	1
50	61-3120-0	Looper avoid eccentric	針返しエキセン王	1
51	75-1140-1	Collar	カラー	1
52	84-5110-0	Screw	ネジ	2
53	49-1390-1	Looper thread take up cam	ハマグリ	1
54	84-7110-0	Screw	ネジ	2
55	75-5340-0	Washer	ワッシャ	1

8. Foot lifter mechanism (押え揚げ機構)

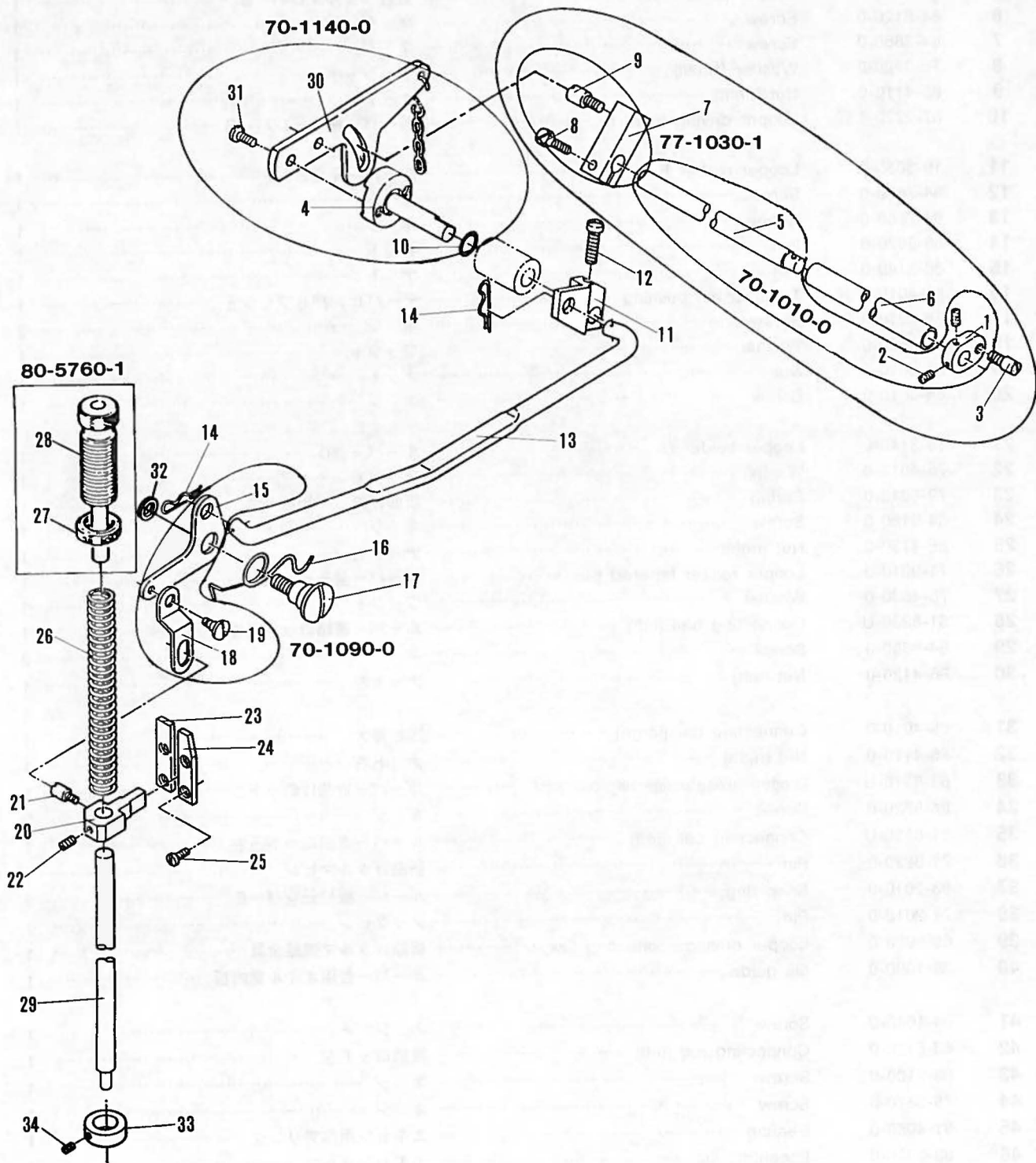

No.	Part No.	Part Name	品名	Q, ty
1	77-1010-0	Lifter lever connector	丸 駒	1
2	84-5210-0	Screw	ネ ジ	2
3	84-5620-0	Screw	ネ ジ	1
4	77-1140-0	Presser foot lifter lever post	押え揚げ土台芯棒	1
5	77-1110-0	Foot lifter crank lever post	押え揚げクランクシャフトA	1
7	77-1210-0	Crank shaft pipe	押え揚げクランクシャフトパイプ A	1
8	84-8120-0	Screw	ネ ジ	1
9	84-5610-0	Screw	ネ ジ	1
10	23-1890-0	O-ring	8-用Oリング	1
11	77-1070-1	Connecting plate	ベアリング用押え揚げ連結板A	1
12	84-7640-0	Screw	ネ ジ	1
13	77-1160-0	Lifter lever connecting bar	押え揚げ連結竿A	1
14	93-6110-0	Snap pin A	スナップピンA	2
15	77-1090-0	Lifter lever spring supporter	押え揚げ巻バネ止め板	1
16	79-2220-0	Lifter lever spring	角型押え揚げ巻バネB	1
17	85-2010-0	Screw	ネ ジ	1
18	77-1310-0	Lift lever link	押え棒抱き連結板	1
19	84-5810-0	Screw	ネ ジ	1
20	77-1330-0	Presser bar guide	押え棒ガイド	1
21	84-5610-0	Screw	ネ ジ	1
22	84-5630-0	Screw	ネ ジ	1
23	77-0350-0	Presser bar connecting guide (left)	押え棒案内板左	1
24	77-0360-0	Presser bar connecting guide (right)	押え棒案内板右	1
25	84-5640-0	Screw	ネ ジ	4
26	79-1210-0	Presser bar spring	押え調節バネ	1
27	86-8510-0	Nut	ナット	1
28	85-7610-0	Screw	ネ ジ	1
29	71-5420-0	Presser bar (small)	押え棒小	1
30	77-8110-0	Presser foot lifter lever	押え揚げコントロールレバーB	1
31	84-5660-0	Screw	ネ ジ	2
32	75-4530-0	Washer	ワッシャ	1
33	75-1540-1	Collar	カラー	1
34	84-5110-0	Screw	ネ ジ	1

9. Puller (プーラー機構)

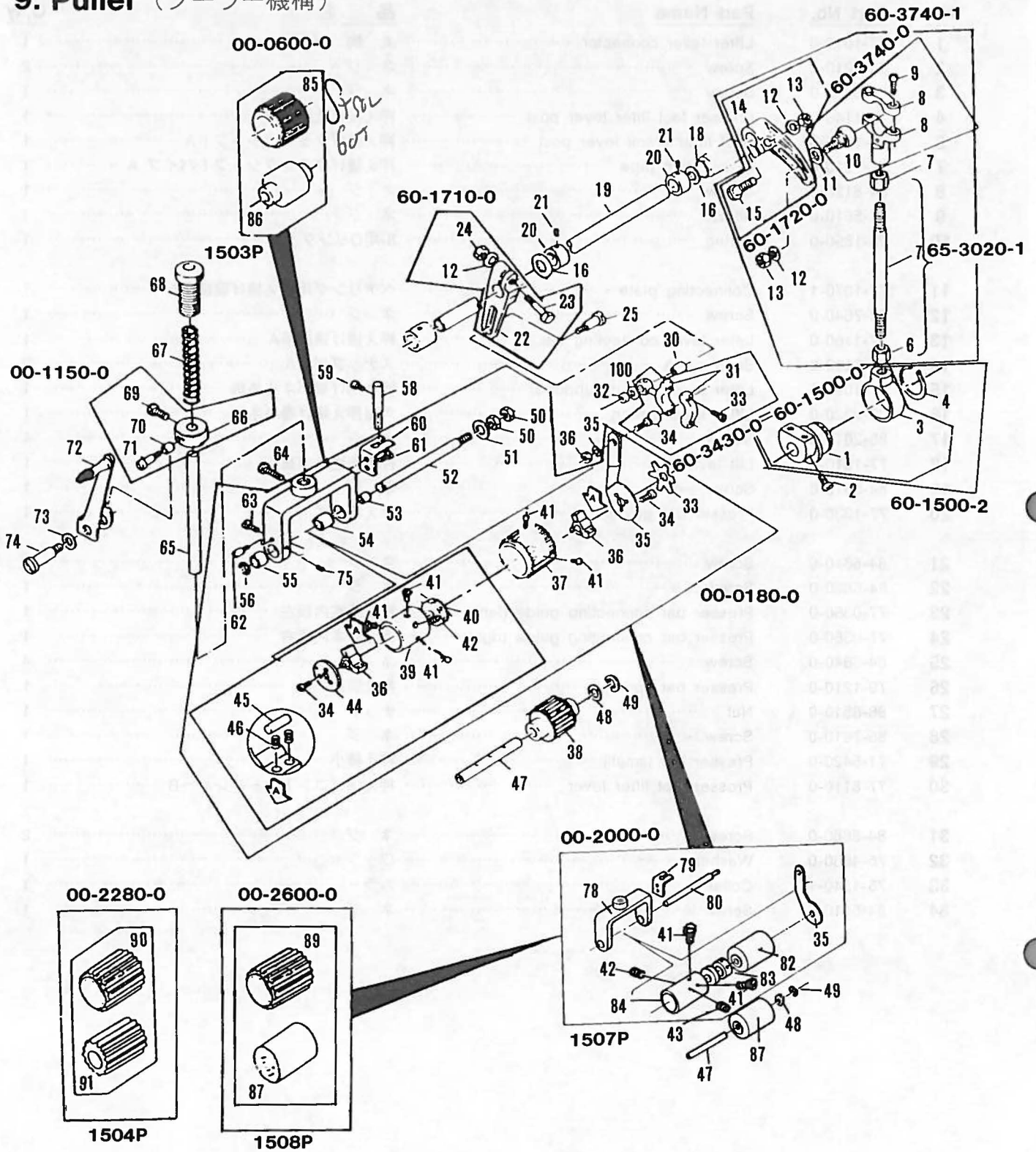

No.	Part No.	Part Name	品名	Q, ty
1	61-2010-U	Puller driving eccentric	連結エキセン玉	1
2	84-7620-0	Screw	ネジ	2
3	63-2010-U	Connecting link	上シャフト連結ダルマ	1
4	93-2510-0	25-Snap ring	25-スナップリング	1
5	86-7410-0	Nut	ナット	1
6	65-3020-0	Puller driving connecting bar	上シャフト連結棒	1
7	86-7420-0	Nut	ナット左	1
8	63-7110-0	Ball joint	立口ット小	1
9	84-5670-0	Screw	ネジ	2
10	61-7140-U	Connecting rod ball	上シャフト連結口ット玉	1
11	75-4910-0	Washer	ワッシャ	1
12	75-5520-0	Washer	M6平座金B	3
13	86-5010-0	Nut	ナット	2

No.	Part No.	Part Name	品名	Q, ty
14	67-1720-0	Puller driving lever (rear)	上シャフト連結ダルマレバー後	1
15	55-0610-0	Pin	送りレバー止めピン	1
16	75-3320-0	Washer	M6平座金	2
18	23-1970-0	O-ring	Oリング	2
19	71-6910-0	Puller driving shaft A	上シャフトA	1
20	75-1130-1	Drive shaft collar	上シャフトカラー大	2
21	84-7180-0	Screw	ネジ	4
22	67-1710-0	Puller driving lever (front)	上シャフト連結レバー前	1
23	85-1910-0	Screw	ネジ	1
24	86-5410-0	Nut	ナット	1
25	84-5840-0	Screw	ネジ	1
26	75-2470-0	Connecting link roller	連結メガネローラーB	1
27	63-8100-1	Puller connecting rod	ウーラー連結ロット	1
28	86-3120-0	Nut	ナット	1
30	61-8100-U	Connecting rod ball	ブーラー連結ロット玉	1
31	75-5520-0	Washer	M6平座金	1
32	86-4110-0	Nut	ナット	1
33	79-5510-0	Puller plate spring	ブーラー板バネ	1
34	84-1620-0	Screw	ネジ	6
35	02-2630-0	Rear puller connecting plate	後ブーラー小用連結板	1
36	02-1010-0	Clutch A	ブーラーBA	2
37	02-2790-0	Rear puller gear 22 teeth (nylon)	後ブーラー上ナイロンギヤー大22山	1
38	02-2990-0	Rear puller gear 18 teeth (nylon)	後ブーラー下ナイロンギヤー大18山	1
39	02-2560-0	Rear puller pipe	後ブーラーパイプ大	1
40	02-2610-0	Rear puller thrust collar	後ブーラースラスト大	1
41	84-4620-0	Screw	ネジ	5
42	84-7190-0	Screw	ネジ	1
43	84-7180-0	Screw	ネジ	1
44	02-1170-0	Rear puller pipe cover	後ブーラーパイプフタ	1
45	71-4660-0	Check clutch roller	ブーラー巴ローラー	6
46	79-1910-0	Check clutch spring	ブーラー巴バネ	12
47	71-6510-0	Rear puller shaft (lower)	後ブーラー下シャフト	1
48	75-3720-0	Washer	ルーパー台シャフトワッシャ小	1
49	02-1160-0	Spring washer	小ローラーシャフト用バネ	1
50	86-7610-0	Nut	ナット	2
51	75-4510-0	Washer	8.1-ワッシャ	1
52	71-4720-0	Rear puller shaft (upper)	後ブーラー台シャフト	1
53	81-3230-0	Puller holder shaft bushing S	ブーラー台シャフトブッシュ小	1
54	81-3220-0	Puller holder shaft bushing M	ブーラー台シャフトブッシュ中	1
55	81-3210-0	Puller holder shaft bushing L	ブーラー台シャフトブッシュ大	1
56	93-2210-0	-8 Snap ring	-8スナップリング (E型止め輪)	1
57	02-2510-0	Rear puller holder	後ブーラー台大	1
58	71-9210-0	Puller guide pin	ブーラー回り止め棒	1
59	84-6150-0	Screw	ネジ	1
60	02-2660-0	Rear puller guide bracket	後ブーラー台用回り止め	1
61	84-6150-0	Screw	ネジ	2
62	84-5730-0	Screw	ネジ	1
63	84-5660-0	Screw	ネジ	1
64	84-8140-0	Screw	ネジ	1
65	71-6370-0	Puller presser shaft	後ブーラー立シャフト	1
66	02-1150-0	Puller shaft holder	ブーラー立シャフト抱き	1
67	79-1260-0	Puller spring	ブーラー巻バネ	1
68	87-7510-0	Puller screw	ネジ	1
69	84-8140-0	Screw	ネジ	1
70	75-2110-0	Lifter lever roller	手揚げ用ローラー	1
71	84-5820-0	Screw	ネジ	1
72	02-1110-0	Lifter lever	手揚げ用金具	1
73	02-1120-0	Lifter spring	手揚げ用バネ	1
74	85-6710-0	Screw	ネジ	1
75	84-5210-0	Screw	ネジ	1
76	75-5520-0	Washer	M6平座金	1
78	02-1510-0	Rear puller holder	後ブーラー台大	1
79	02-1660-0	Rear puller guide bracket	後ブーラー台大用回り止MB	1
80	71-4710-0	Rear puller shaft (upper)	後ブーラー台シャフト大	1
82	02-1810-2	Rear puller (smooth)	後ブーラー上ゴム大丸	1
83	02-1610-0	Rear puller thrust collar	後ブーラースラスト小	1
84	02-1560-0	Rear puller pipe	スラスト	1
85	02-2810-0	Rear puller gear 60teeth (shaft)	後ブーラー60山上ギヤー小	1
86	02-3010-2	Rear puller (smooth)	後ブーラー下ゴム小丸	1
87	02-1970-2	Rear puller (smooth)	後ブーラー下ゴム大丸 (PSF,WB)	1
88	02-1840-0	Rear puller rouletted roller (steel)	後ブーラー上ローレット (WB)	1
89	02-1750-0	Rear puller gear 60teeth (steel)	後ブーラー60山上ギヤー大	1
90	02-1780-0	Rear puller gear 28teeth (nylon)	後ブーラー上ナイロンギヤー大28山	1
91	02-2080-0	Rear puller gear 23teeth (nylon)	後ブーラー下ナイロンギヤー大23山	1

10. Gauge parts(1)ゲージ関係(1)

1501PHD
1501P

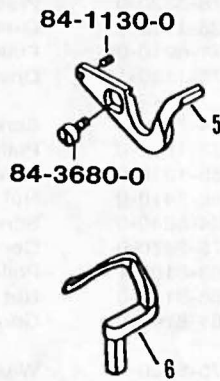
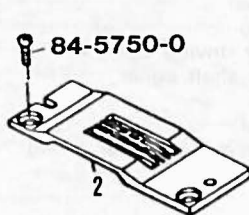
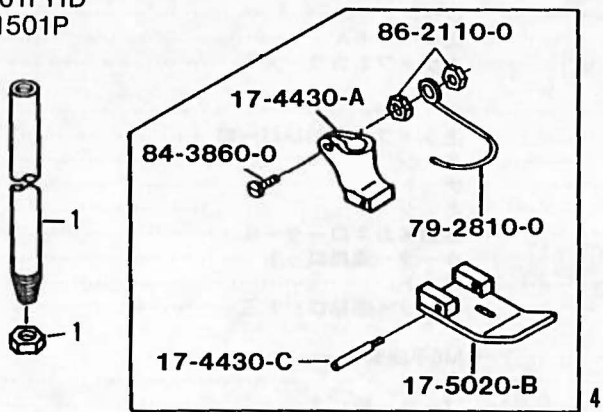

1502P, PMD 3/16

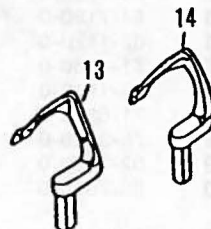
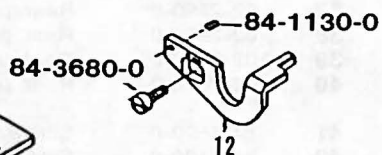
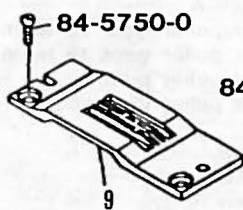
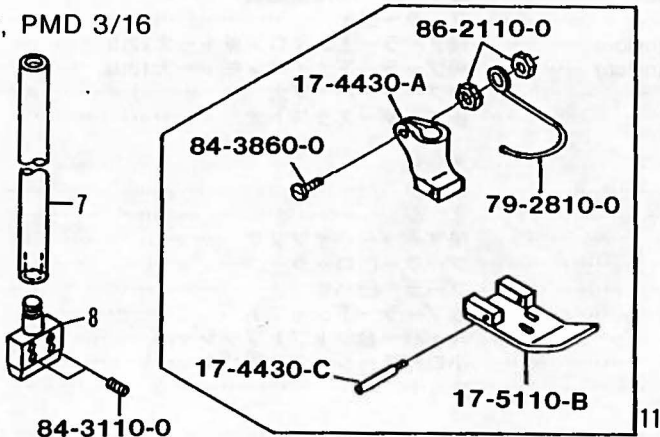

1502P, PMD 1/4

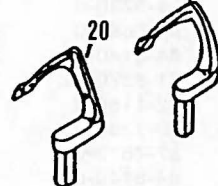
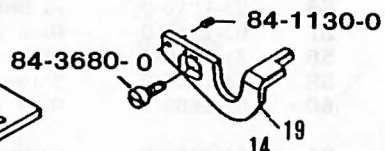
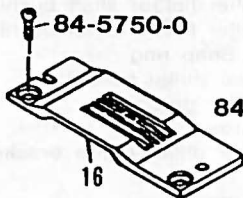
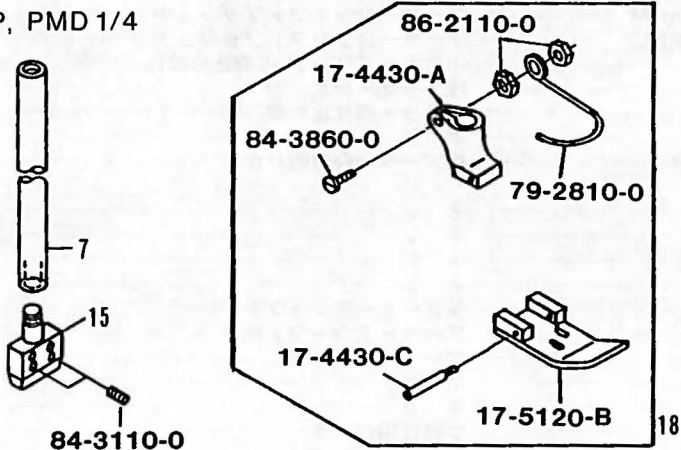

1502P, PMD 5/16

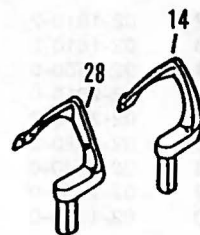
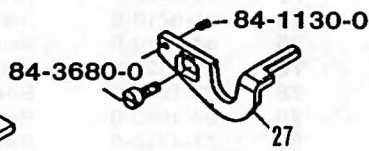
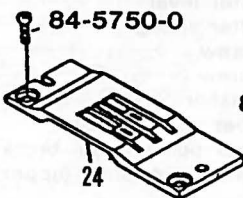
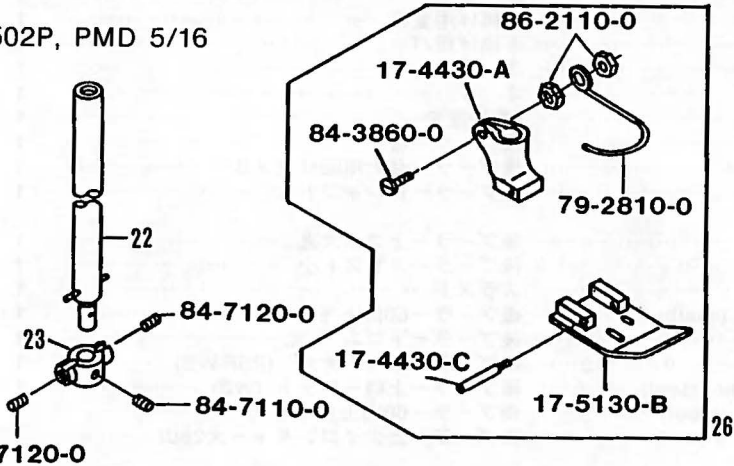

11.Gauge parts(2) ゲージ関係(2)

1502PHD 1/4

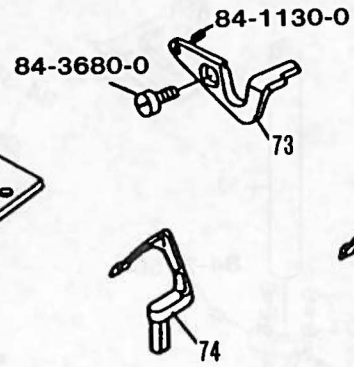
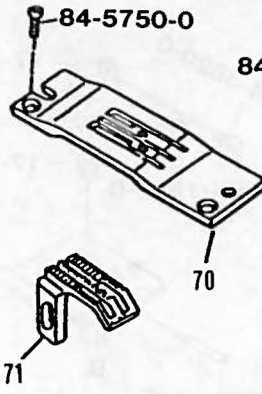
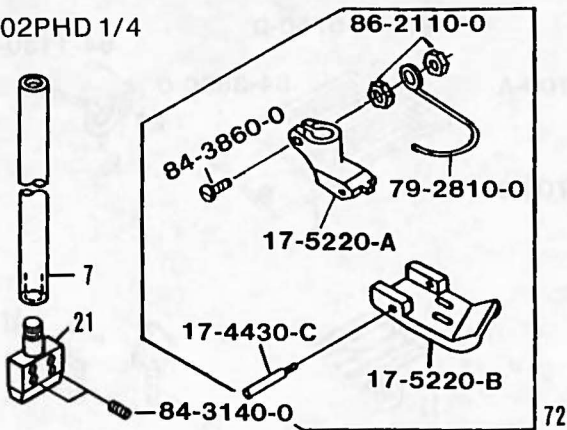

1503PHD 1/4

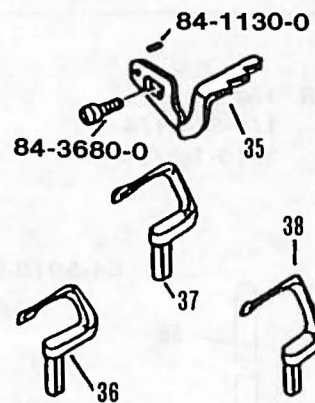
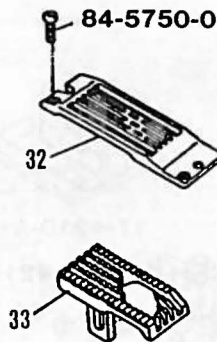
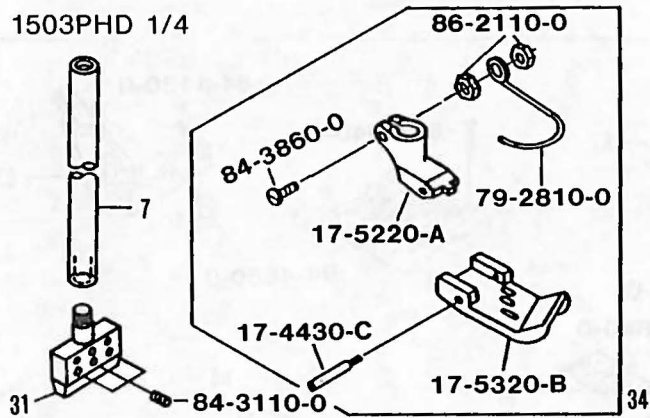

1503PTF 1/4, 9/32

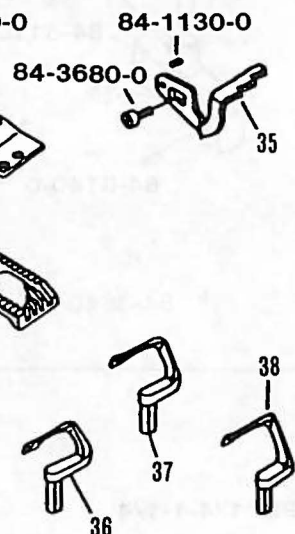
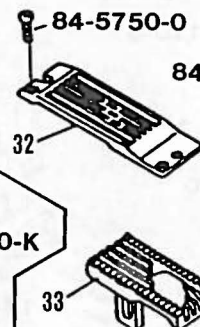
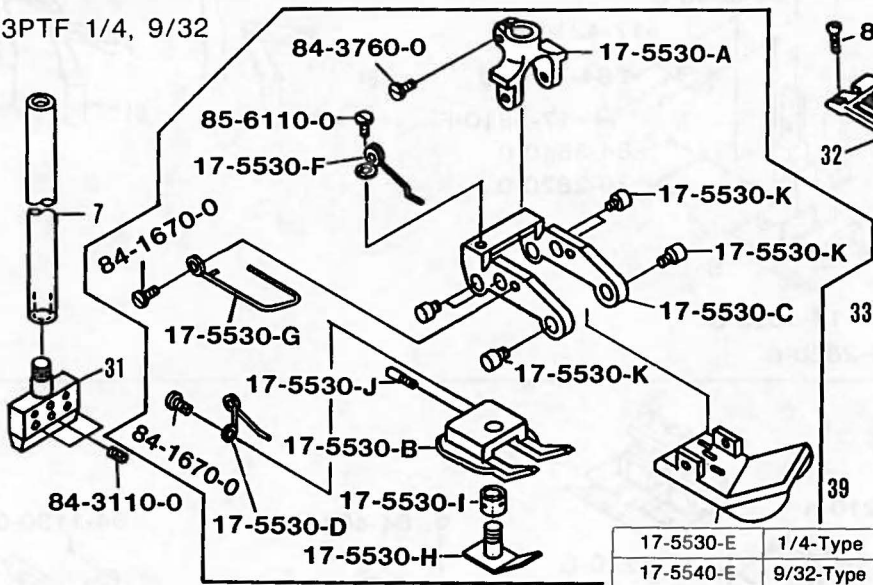

1504P, PMD 1", 1 1/8

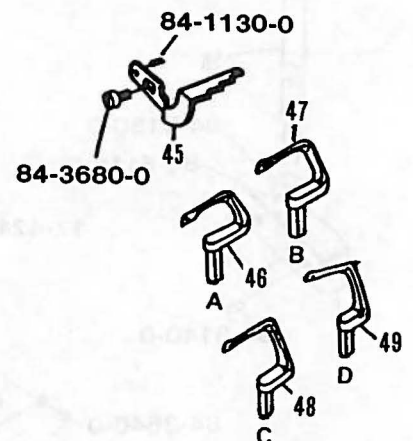
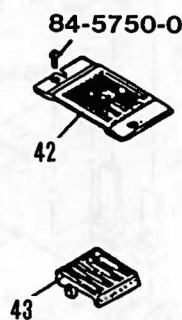
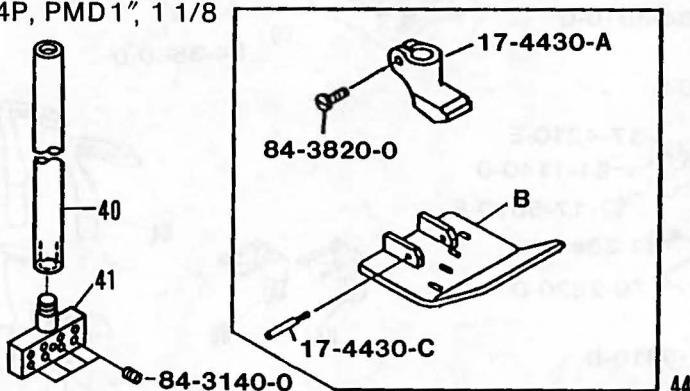

12. Gauge parts(3)ゲージ関係(3)

1507P 7/8, 1", 1"1/8, 1"1/4, 1"1/2

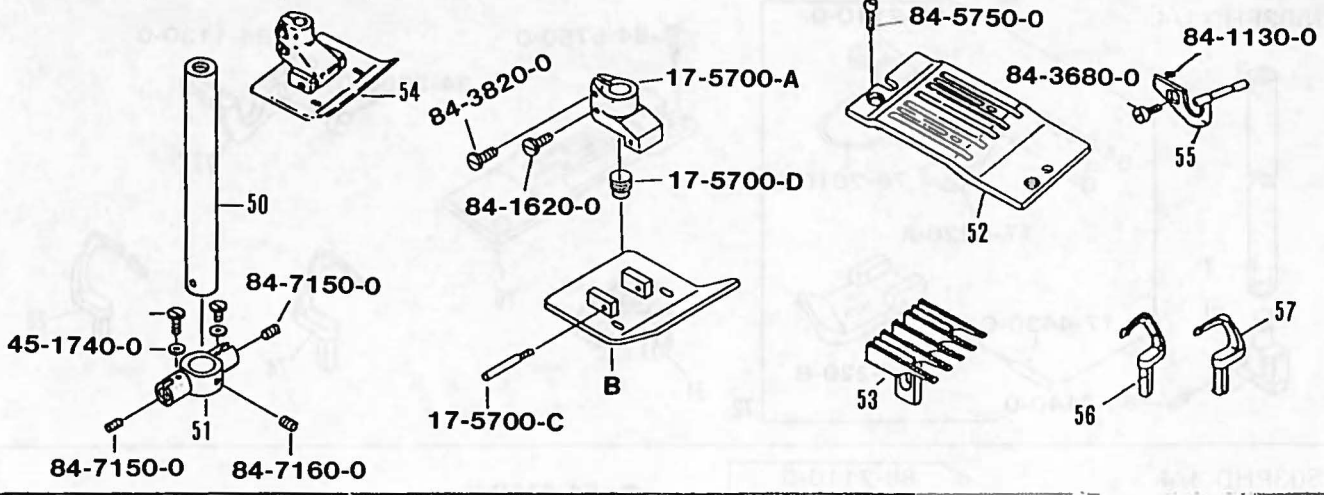

1508P, PR 1/4-1-1/4
1/4-3/4-1/4
3/16-1-3/16

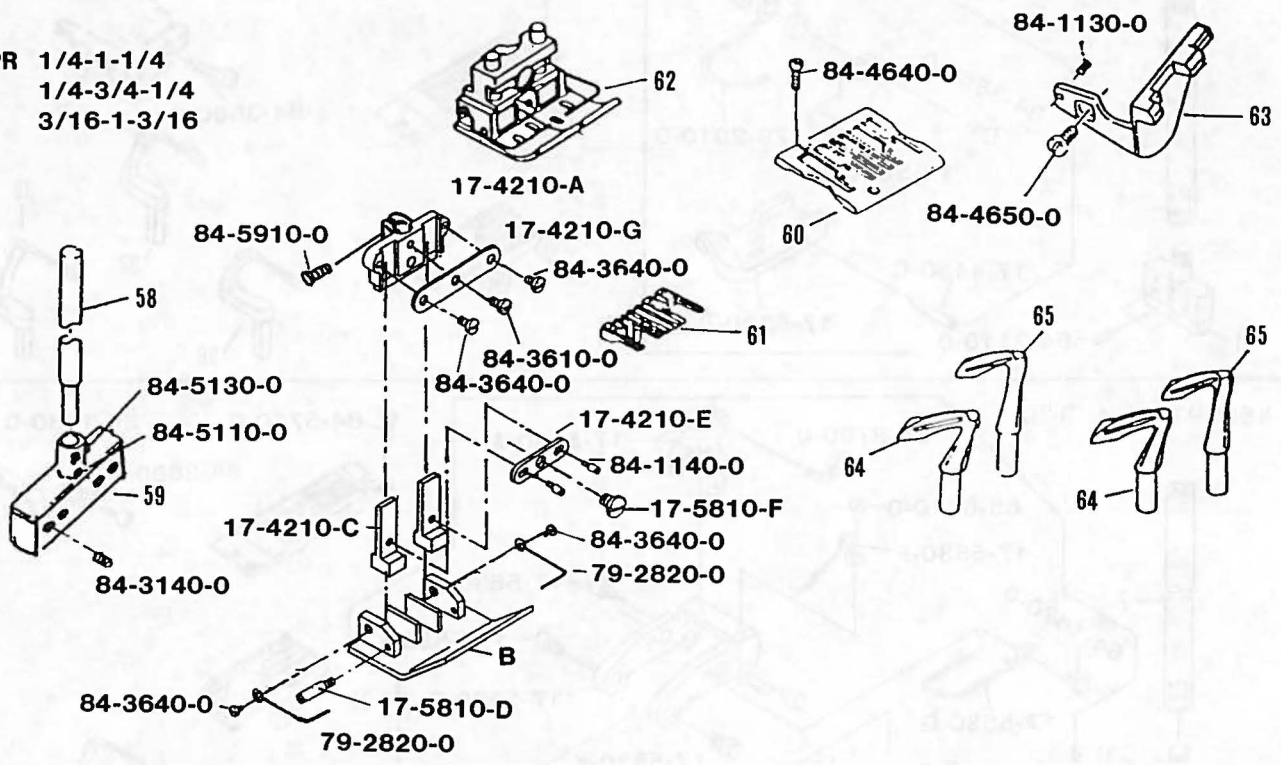

1508PD 1/4-1-1/4

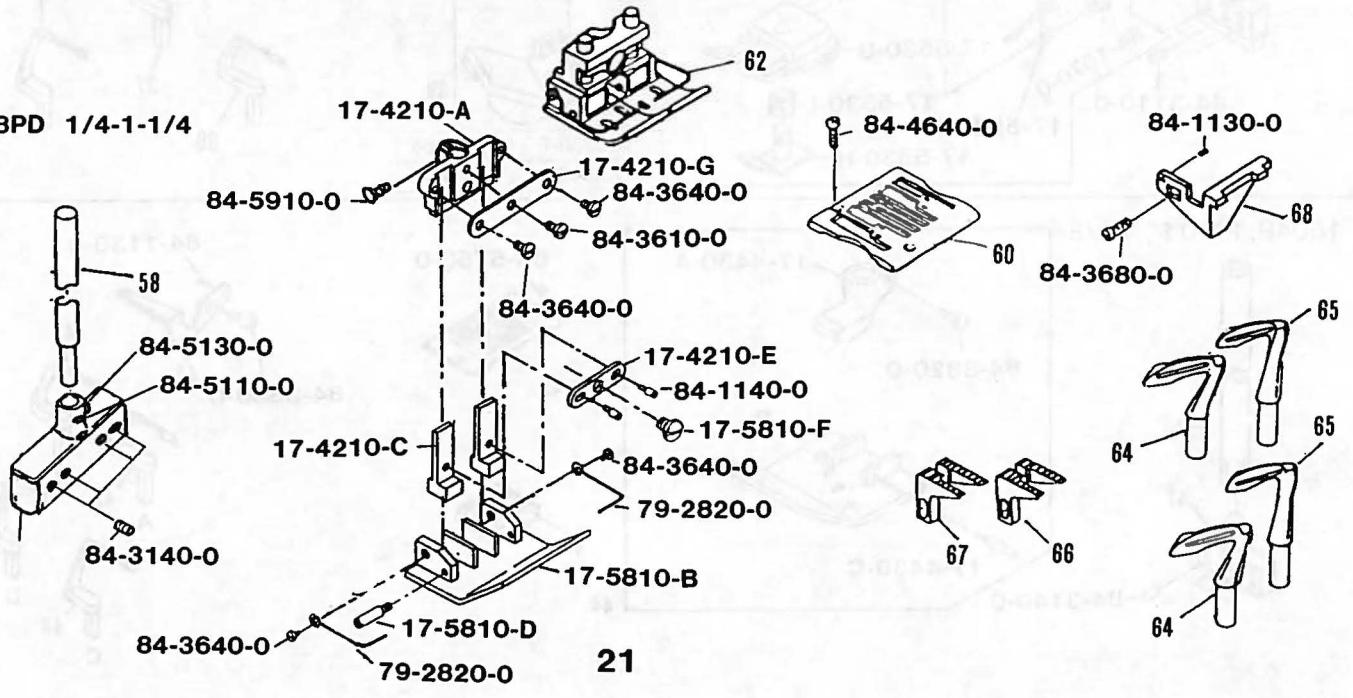

13. DLR-P Series gauge parts index (DLR-シリーズパーツ一覧表)

Model 機種	Needle bar		Needle holder		Needle plate		Feed dog		Presser foot		Needle guard		Looper				Looper holder	
	No.	針 棒	No.	針 株	No.	針 板	No.	送り歯	No.	押 え	No.	針 受 け	No.	ルーバー	No.	ルーバー	No.	ルーバー台
1501PHD	1	11-5040-0			2	14-5020-0	3	15-5020-0	4	17-5020-1	5	18-5010-0	6	19-5350-0				10-9150-1
1502P, PMD 3/16	7	11-7040-0	8	12-5110-1	9	14-5110-0	10	15-5110-0	11	17-5110-1	12	18-5200-0	13	19-5110-0	14	19-5180-0		10-9140-1
1/4	7	11-7040-0	15	12-5120-1	16	14-5120-0	17	15-5120-0	18	17-5120-1	19	18-5210-0	20	19-5120-0	14	19-5180-0		10-9140-1
5/16	22	11-5010-0	23	12-5130-1	24	14-5130-0	25	15-5130-0	26	17-5130-1	27	18-5210-0	28	19-5130-0	14	19-5180-0		10-9140-1
1502PHD 1/4	7	11-7040-0	21	12-5220-1	70	14-5220-0	71	15-5220-0	72	17-5220-1	73	18-5220-0	74	19-5210-0	29	19-5220-0		10-9180-1
1503PHD 1/4	7	11-7040-0	31	12-5530-1	32	14-5530-0	33	15-5530-0	34	17-5320-1	35	18-5310-0	36	19-5310-0	38 37	19-5360-0 19-5350-0		10-9160-1
1503PTF 1/4	7	11-7040-0	31	12-5530-1	32	14-5530-0	33	15-5530-0	39	17-5530-1	35	18-5310-0	36	19-5310-0	38 37	19-5360-0 19-5350-0		10-9160-1
9/32	7	11-7040-0	31	12-5540-1	32	14-5540-0	33	15-5530-0	39	17-5540-1	35	18-5310-0	36	19-5530-0	38 37	19-5550-0 19-5540-0		10-9160-1
1504P, PMD 1"	40	11-4020-0	41	12-5410-1	42	14-5410-0	43	15-5410-0	44	17-5410-1	45	18-5410-0	48 46	19-5480-0 19-5460-0	49 47	19-5490-0 19-5470-0		10-9120-1
1"1/8	40	11-4020-0	41	12-5420-1	42	14-5420-0	43	15-5420-0	44	17-5420-1	45	18-5420-0	48 46	19-9910-0 19-9580-0	49 47	19-9920-0 19-9900-0		10-9120-1
1507P 7/8	50	11-5030-0	51	12-5700-1	52	14-5700-0	53	15-5700-0	54	17-5700-1	55	18-5700-0	56	19-5710-0	57	19-5720-0		10-9730-1
1"	50	11-5030-0	51	12-5710-1	52	14-5710-0	53	15-5710-0	54	17-5710-1	55	18-5700-0	56	19-5710-0	57	19-5720-0		10-9730-2
1"1/8	50	11-5030-0	51	12-5720-1	52	14-5720-0	53	15-5720-0	54	17-5720-1	55	18-5720-0	56	19-5710-0	57	19-5720-0		10-9730-3
1"1/4	50	11-5030-0	51	12-5730-1	52	14-5730-0	53	15-5730-0	54	17-5730-1	55	18-5720-0	56	19-5710-0	57	19-5720-0		10-9730-4
1"1/2	50	11-5030-0	51	12-5740-1	52	14-5740-0	53	15-5740-0	54	17-5740-1	55	18-5720-0	56	19-5710-0	57	19-5720-0		10-9730-5
1508P, PR 1/4-1-1/4	58	11-4010-0	59	12-5810-1	60	14-5810-0	61	15-5810-0	62	17-5810-1	63	18-5740-0	64	19-5810×2	65	19-5820×2		10-9840-1
1508P 1/4-3/4-1/4	58	11-4010-0	59	12-5830-1	60	14-5830-0	61	15-5830-0	62	17-5830-1	63	18-5830-0	64	19-5810×2	65	19-5820×2		10-9730-2
3/16-1-3/16	58	11-4010-0	59	12-5820-1	60	14-5820-0	61	15-5820-0	62	17-5820-1	63	18-5820-0	64	19-5810×2	65	19-5830×2		10-9840-2
1508PD 1/4-1-1/4	58	11-4010-0	59	12-5810-1	60	14-5810-0	67 66	98-1240-0 98-1190-0	62	17-5810-1	68	98-1200-0	64	19-5810×2	65	19-5820×2		10-9840-1

Subclass models (サブクラス機種) 1502PMD・1504PMD

14. Front puller mechanism (前プーラー装置)

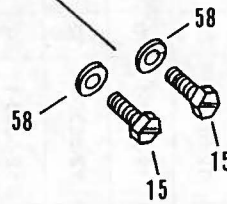
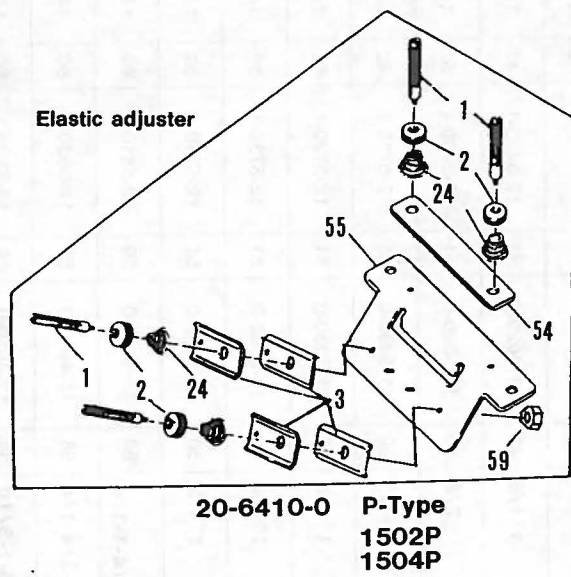
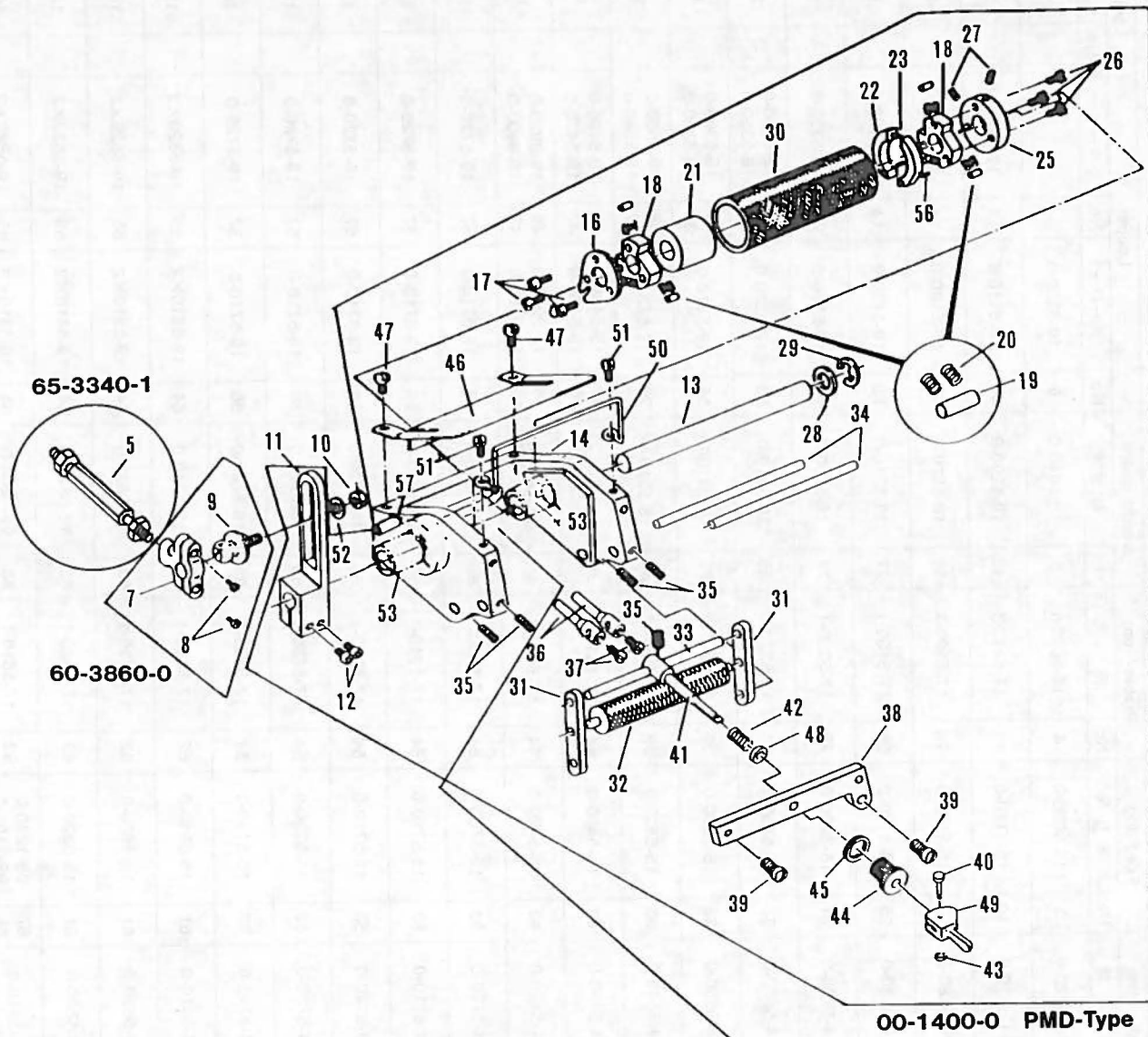

No.	Part No.	Part Name	品名	Q, ty
1	26-4060-0	Tension Post	ゴム調節用調子棒小	4
2	26-4080-0	Nut	ナット	4
3	26-4030-0	Strip tension plate (small)	ゴム調節押え金具	4
5	65-3340-1	Puller connecting bar	前プーラー連結棒	1
7	63-8120-1	Connecting ball joint	連結ロッド左	1
8	84-5670-0	Screw	ネジ	2
9	61-8210-U	Connecting rod ball A	針振りリングロッド玉A	1
10	86-5010-0	Nut	ナット	1
11	67-1810-0	Puller connecting lever	前プーラー連結レバー	1
12	85-6810-0	Screw	ネジ	2
13	71-5240-0	Puller rocker shaft	前プーラー土台シャフトB	1
14	01-1110-0	Puller rocker	前プーラー土台	1
15	84-8130-0	Screw	ネジ	2
16	01-1160-0	Puller clutch driving collar	前プーラー回り止め蓋	1
17	84-1620-0	Screw	ネジ	3
18	02-1010-0	Puller driving clutch	プーラー巴A	2
19	71-4660-0	Puller clutch roller	プーラー巴ローラー	6
20	79-1910-0	Puller driving clutch spring	プーラー巴バネ	12
21	01-1210-0	Puller thrust collar	前プーラースラスト	1
22	01-1240-0	Brake	ブレーキ片	2
23	79-1940-0	Brake spring	ブレーキ巻バネ	1
24	26-4070-0	Spring	ゴム調節用調子バネ	4
25	01-1180-0	Clutch driving collar	前プーラー蓋	1
26	84-1620-0	Screw	ネジ	3
27	84-7180-0	Screw	ネジ	2
28	75-4510-0	Washer	ワッシャ	1
29	93-2210-0	E-ring	8-ストップリング (E型止め輪)	1
30	01-1310-0	Puller pipe	前プーラーローレットパイプ	1
31	01-1360-0	Roller holder	前プーラー小ローラー取付金具	2
32	01-1340-0	Roller	前プーラー小ローラー	1
33	71-3620-0	Pivot shaft (small)	案内棒小	1
34	71-3610-0	Pivot shaft (large)	案内棒大	2
35	84-3140-0	Screw	ネジ	5
36	01-1380-0	Pivot shaft holder	前プーラーゴム案内金具	2
37	84-1620-0	Screw	ネジ	2
38	01-1410-0	Rubber tightener	前プーラー締め金具B	1
39	84-5660-0	Screw	ネジ	2
40	01-1470-0	Pin	ワンタッチレバー連結ピン	1
41	01-1430-0	Roller controler	小ローラー締め金具	1
42	79-1710-0	Spring	圧縮バネ中	1
43	93-2000-0	E-ring	3-ストップリング (E型止め輪)	1
44	87-4560-0	Screw	ネジ	1
45	88-4560-0	Nut	ナット	1
46	01-1460-0	Puller cover	前プーラーカバー	1
47	84-3610-0	Screw	ネジ	2
48	75-4460-0	Washer	ワッシャ	1
49	01-1450-0	Lever	前プーラー用ワンタッチレバー金具B	1
50	01-1520-0	Guide wire	前プーラー台取付ガイド	1
51	84-5710-0	Screw	ネジ	2
52	75-3810-0	Washer	ワッシャ	1
53	81-1250-0	Bushing	前プーラー土台ブッシュ	2
54	26-4010-0	Stip tension plate	ゴム調節取付板	1
55	26-4020-0	Stip tension base	ゴム調節取付金具	1
56	84-1190-0	Screw	ネジ	2
57	71-2270-0	Pin	テーバーピン	1
58	75-4520-0	Washer	ワッシャ	2
59	86-3110-0	Nut	ナット	2

Subclass model (サブクラス機種)

15. 1501P-HD/1502P-HD

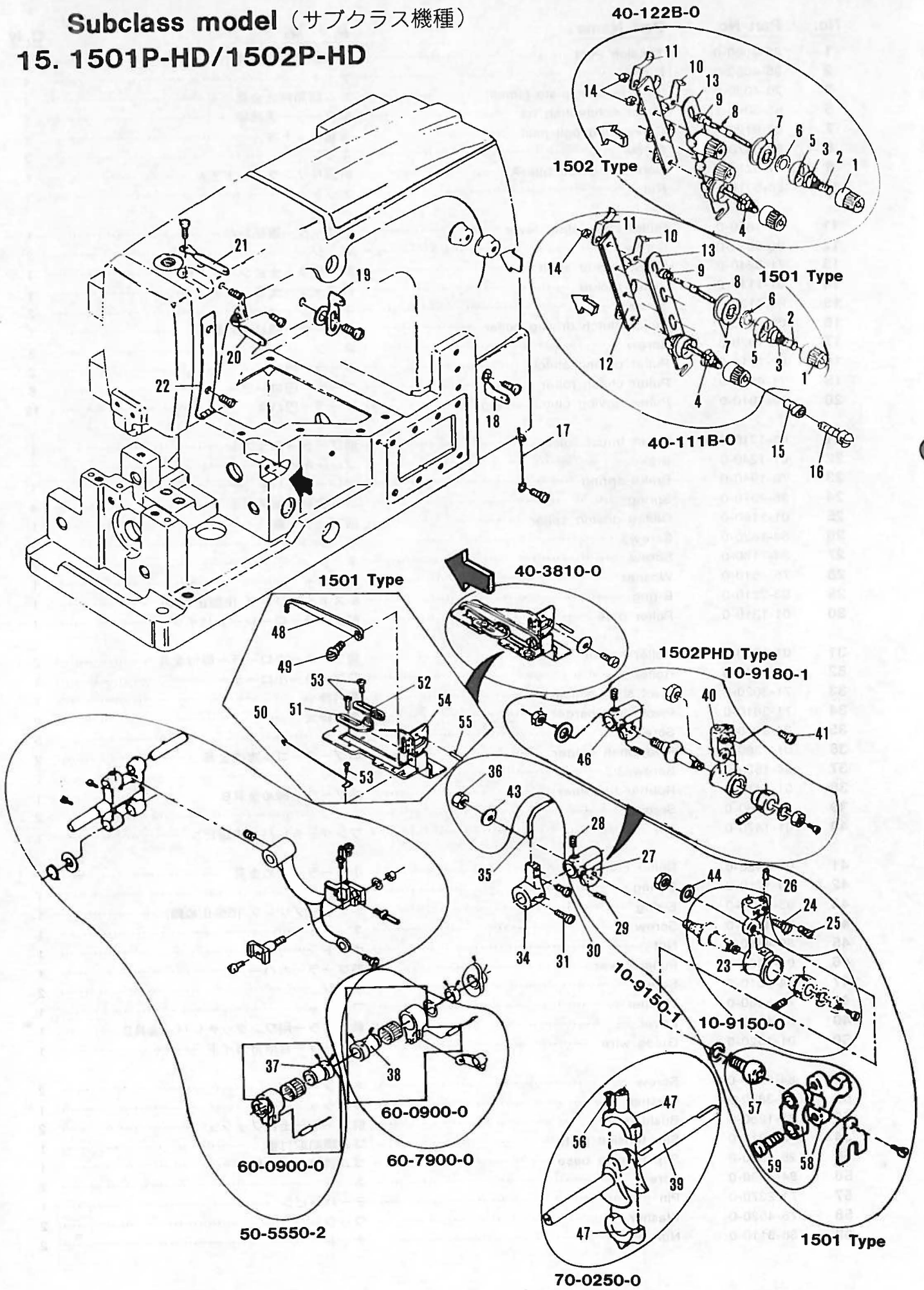

No.	Part No.	Part Name	品名	Q, ty
1	41-1010-0	Adjusting nut	チャンボン皿小ケース	2
2	41-1050-0	Adjusting ratchet	チャンボン皿ラチェット	2
3	41-7010-0	Spring (strong)	チャンボン調子バネ強	1
4	41-7020-0	Spring (weak)	チャンボン調子バネ弱	1
5	41-1070-0	Disc cover	チャンボン皿大ケース	2
6	23-3240-0	Felt	取付フェルト	2
7	41-1110-0	Disc	チャンボン皿	4
8	41-1720-0	Tension post	調子棒中	2
9	41-1310-0	Tension post collar A	調子棒カラー A	2
10	41-1150-0	Tension post thread eyelet	糸道上	2
11	41-1170-0	Thread eyelet	糸道下	2
12	42-121B-0	Tension post holder	チャンボン調節元板	1
13	41-113B-0	Tension post support	チャンボン調節板	1
14	86-4110-0	Nut	ナット	1
15	41-1320-0	Tension post collar	調子棒カラー	1
16	84-7640-0	Screw	ネジ	1
17	47-2040-0	Looper thread guide eyelet	下糸案内糸道	1
18	47-2010-0	Looper thread guide eyelet	下糸案内糸道	1
19	45-1090-0	Needle thread eyelet	上糸糸道	1
20	45-1290-0	Needle lever thread eyelet	弓糸道	1
21	45-1390-0	Needle bar thread eyelet	針棒糸道	1
22	45-1510-0	Needle thread guide	上糸ガイド	1
23	19-3150-0	Looper holder E	ルーバー台 E	1
24	84-6160-0	Screw	ネジ	1
25	84-5210-0	Screw	ネジ	1
26	71-2160-0	Adjust pin	ルーバーアジャストピン	1
27	19-3030-0	Looper rocker C	ルーバー元台 C	1
28	84-7660-0	Screw	ネジ	1
29	84-7670-0	Screw	ネジ	1
30	84-1620-0	Screw	ネジ	1
31	84-8160-0	Screw	ネジ	1
34	18-7220-0	Needle bar guide bracket A	針ガイドブラケット A	1
35	18-7250-0	Needle bar guide C	針ガイド C	1
36	86-5020-0	Nut	ナット	1
37	61-3220-0	Eccentric B (0.9)	エキセン玉 B (0.9)	1
38	61-3220-0	Eccentric B (0.9)	エキセン玉 B (0.9)	1
39	71-8520-0	Crank shaft 5HB	クランクシャフト 5HB	1
40	19-3180-0	Looper holder H	ルーバー台 H	1
41	84-6160-0	Screw	ネジ	1
43	75-3810-0	Washer	ワッシャ	1
44	75-4530-0	Washer	ワッシャ	1
45	86-4130-0	Nut	ナット	1
46	19-3050-0	Looper rocker D	ルーバー元台 D	1
47	63-6210-1	Crank shaft ball joint	立ロッド大	1
48	43-3440-0	Retainer upper	下糸捌き上	1
49	84-3740-0	Screw	ネジ	1
50	43-3350-0	Looper thread retainer wire	下糸捌き下ピンB	1
51	47-1310-0	Looper thread guide eyelet (right)	下糸捌き板案内糸道右	1
52	47-1320-0	Looper thread guide eyelet (left)	下糸捌き板案内糸道左	1
53	84-1610-0	Screw	ネジ	3
54	43-3310-0	Cast-off support bracket	下糸捌き上取付台	1
55	71-1910-0	Pin	下糸捌きノックピン	2
56	84-5680-0	Screw	ネジ	2
57	61-8230-U	Connecting ball (left)	ルーバー連結ロッド玉 左	1
58	63-8120-1	Connecting rod (left)	連結ロッド 左	1

Subclass model (サブクラス機種)

16. 1503P-TF/1503P-HD

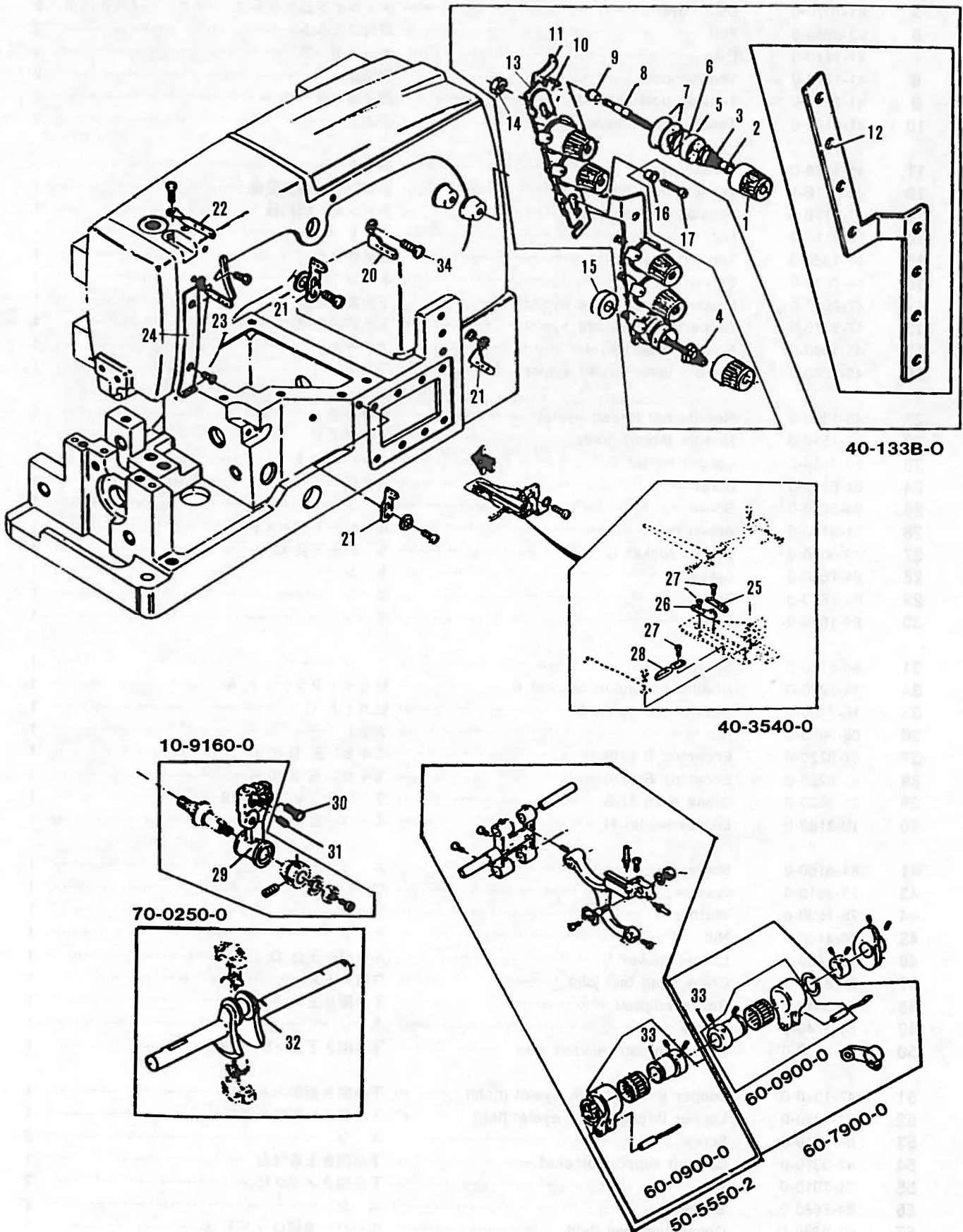

No.	Part No.	Part Name	品 名	Q, ty
1	41-1010-0	Adjusting nut	チャンボン皿小ケース	6
2	41-1050-0	Adjusting ratchet	チャンボン皿ラチェット	6
3	41-7010-0	Spring (strog)	チャンボン調子バネ強	3
4	41-7020-0	Spring (weak)	チャンボン調子バネ弱	3
5	41-1070-0	Disc cover	チャンボン皿大ケース	6
6	23-3240-0	Felt	取付フェルト	6
7	41-1110-0	Disc	チャンボン皿	12
8	41-1720-0	Tension post	調子棒中	6
9	41-1310-0	Tension post collar A	調子棒カラーA	6
10	41-1150-0	Tension post thread eyelet	糸道上	6
11	41-1170-0	Thread eyelet	糸道下	6
12	41-123B-0	Tension post holder (large)	チャンボン調節元板 (大)	1
13	41-113B-0	Tension post support	チャンボン調節板	1
14	86-4110-0	Nut	ナット	5
15	41-1360-0	Cushion rubber	クッションゴム	1
16	41-1320-0	Tension post collar B	調子棒カラーB	1
17	84-7640-0	Screw	ネジ	1
20	47-1660-0	Looper thread eyelet	チャンボン皿カバー糸道	1
21	45-1020-0	Needle thread eyelet (upper)	上糸糸道上	3
22	45-1320-0	Tension post collar B	調子棒カラーB	1
23	45-1220-0	Needle lever thread eyelet B	弓糸道B	1
24	45-1510-0	Needle thread guide A	上糸ガイドA	1
25	47-1270-0	Looper thread guide eyelet (right)	下糸捌き糸案内 (右)	1
26	47-1280-0	Looper thread guide eyelet (left)	下糸捌き糸案内 (左)	1
27	84-1610-0	Screw	ネジ	4
28	47-1210-0	Looper thread eyelet	下糸捌き板糸道	1
29	19-3160-0	Looper holder F	ルーパー台F	1
30	34-6160-0	Screw	ネジ	2
31	84-5210-0	Screw	ネジ	1
32	71-8520-0	Crank shaft 5HB	クランクシャフト5HB	1
33	61-3220-0	Eccentric B (0,9)	エキセン玉 (0,9)	2
34	84-5710-0	Screw	ネジ	1

17. 1504P Subclass model (サブクラス機種)

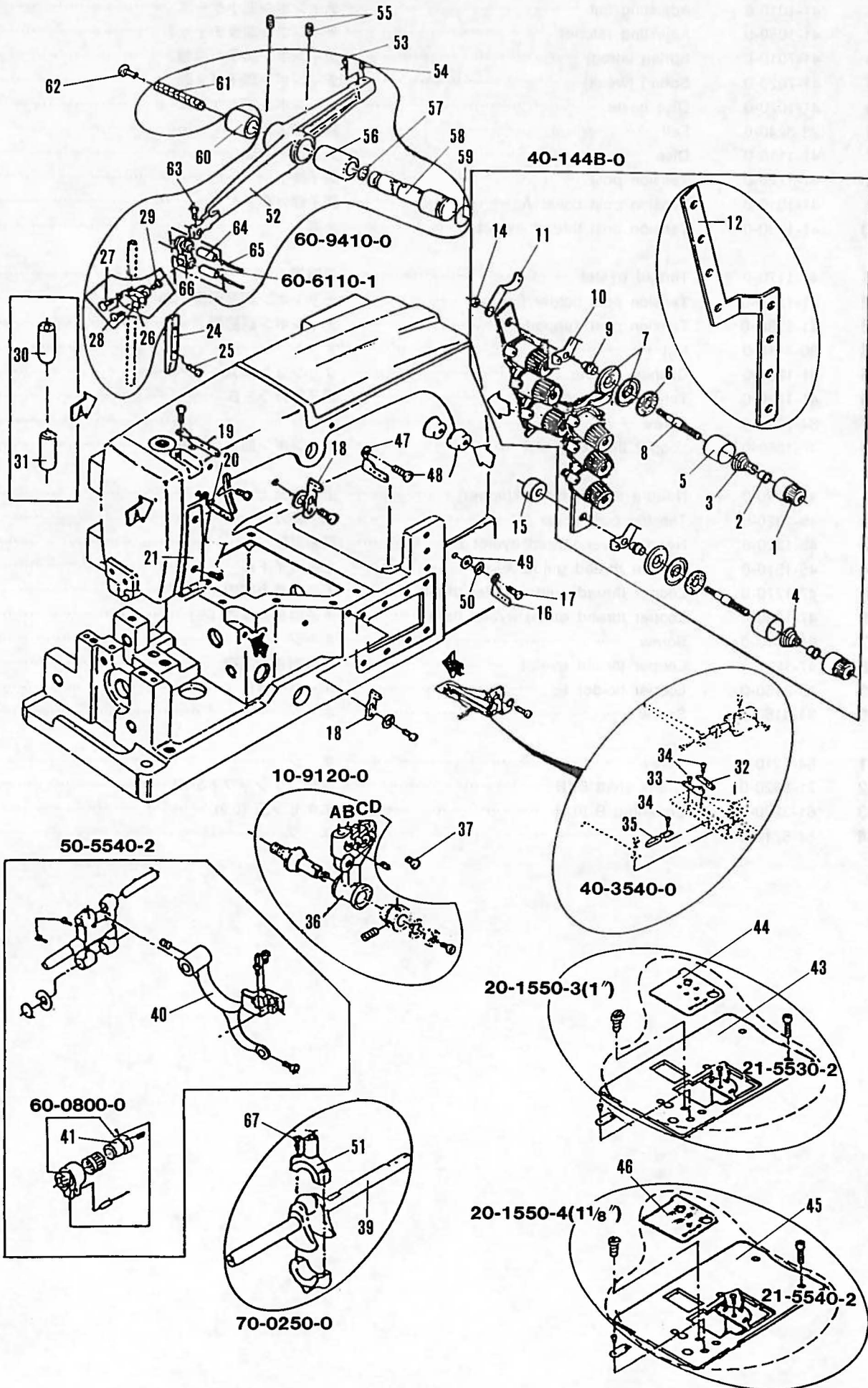

No.	Part No.	Part Name	品 名	Q, ty
1	41-1010-0	Adjusting nut	チャンボン皿小ケース	8
2	41-1050-0	Adjusting ratchet	チャンボン皿ラチェット	8
3	41-7010-0	Spring (strong)	チャンボン調子バネ強	4
4	41-7020-0	Spring (weak)	チャンボン調子バネ弱	4
5	41-1070-0	Disc cover	チャンボン皿大ケース	8
6	23-3240-0	Felt	取付フェルト	8
7	41-1110-0	Disc	チャンボン皿	16
8	41-1720-0	Tension post	調子棒中	8
9	41-1310-0	Tension post collar A	調子棒カラー A	8
10	41-1150-0	Tension post thread eyelet	糸道 上	8
11	41-1170-0	Thread eyelet	糸道 下	8
12	42-123B-0	Tension post holder (large)	チャンボン調節元板 大	1
13	41-113B-0	Tension post support	チャンボン調節板	1
14	86-4110-0	Nut	ナット	6
15	41-1360-0	Rubber	チャンボンクッションゴム	1
16	45-1030-0	Looper thread eyelet 4	チャンボン皿カバー糸道 4穴	1
17	84-5660-0	Screw	ネジ	1
18	45-1030-0	Needle thread eyelet 4	上糸糸道 上 4穴	2
19	45-1330-0	Needle bar thread eyelet 4	針棒糸道 4穴	1
20	45-1230-0	Needle lever thread eyelet 4	弓糸道 4穴	1
21	45-1520-0	Needle thread guide 4	上糸ガイド 4穴	1
24	69-1170-0	Needle bar guide plate	針棒案内板	1
25	84-5740-0	Screw	ネジ	2
26	73-1210-0	Needle bar clamp	針棒コネクタガイド	1
27	84-6150-0	Screw	ネジ	1
28	84-3630-0	Screw	ネジ	1
29	84-3650-0	Screw	ネジ	1
30	81-1820-0	Needle bar bushing (lower)	針棒ブッシュB下	1
31	81-1810-0	Needle bar bushing (upper)	針棒ブッシュB上	1
32	47-1270-0	Looper thread guide eyelet (right)	下糸捌き糸案内 (右)	1
33	47-1280-0	Looper thread guide eyelet	下糸捌き糸案内 (左)	1
34	84-1610-0	Screw	ネジ	3
35	47-1210-0	Looper thread eyelet	下糸捌き板糸道	1
36	19-3120-0	Looper holder E	ルーバー台 B	1
37	84-6160-0	Screw	ネジ	3
38	84-5210-0	Screw	ネジ	1
39	71-8520-0	Crank shaft 5HB	クランクシャフト	1
40	55-1540-0	Feed rocker	送り土台	1
41	61-3220-0	Eccentric 0.9 (for feed)	送りエキセン玉	1
43	21-5530-0	Upper cloth plate	上ベースカバー	1
44	21-5230-0	Slide plate	差板	1
45	21-5540-0	Upper cloth plate	上ベースカバー	1
46	21-5240-0	Slide plate	差板	1
47	47-1040-0	Looper thread eyelet 4	チャンボン皿カバー糸道	1
48	84-5710-0	Screw	ネジ	1
49	23-1870-0	O-ring	Oリング	1
50	75-4550-0	Washer	ワッシャ	1
51	63-6210-1	Crank shaft ball joint	立ロッド大	1
52	69-1050-2	Needle lever E	弓 E	1
53	85-2120-0	Screw	ネジ	1
54	85-1130-0	Screw	ネジ	1
55	85-1140-0	Screw	ネジ	2
56	81-1130-0	Needle lever bushing	弓ブッシュ	1
57	75-3320-0	Washer	ワッシャ t=1.5	1
58	71-9330-0	Needle lever stud	角型弓ピン	1
59	23-1950-0	O-ring	弓ピン油止め用Oリング	1
60	81-4120-0	Needle lever stud bushing	弓ピンブッシュB	1
61	23-3960-0	Felt	フェルト	1
62	85-1810-0	Screw	ネジ	1
63	84-3660-0	Screw	ネジ	1
64	71-4320-0	Needle bar connecting link pin	メガネピン	2
65	23-3410-0	Felt	メガネピン用フェルト	2
66	73-1210-1	Needle bar clamp	針棒クランプ	1
67	84-5680-0	Screw	ネジ	2

18. 1507P Sudclass model (サブクラス機種)

No	Set No	Gauge	Set No
1,5	20-155W-3	7/8, 1"	21-5530-2
2,6	20-155W-4	1-1/8"	21-5540-2
3,7	20-155W-5	1-1/8"	21-5550-2
4,8	20-155W-6	1-1/2"	21-5560-2

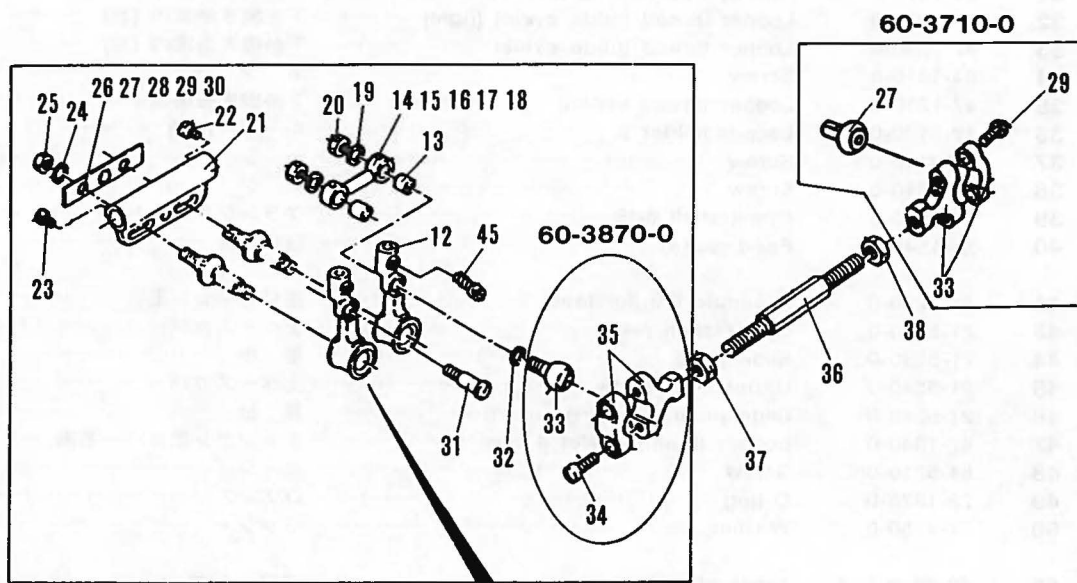
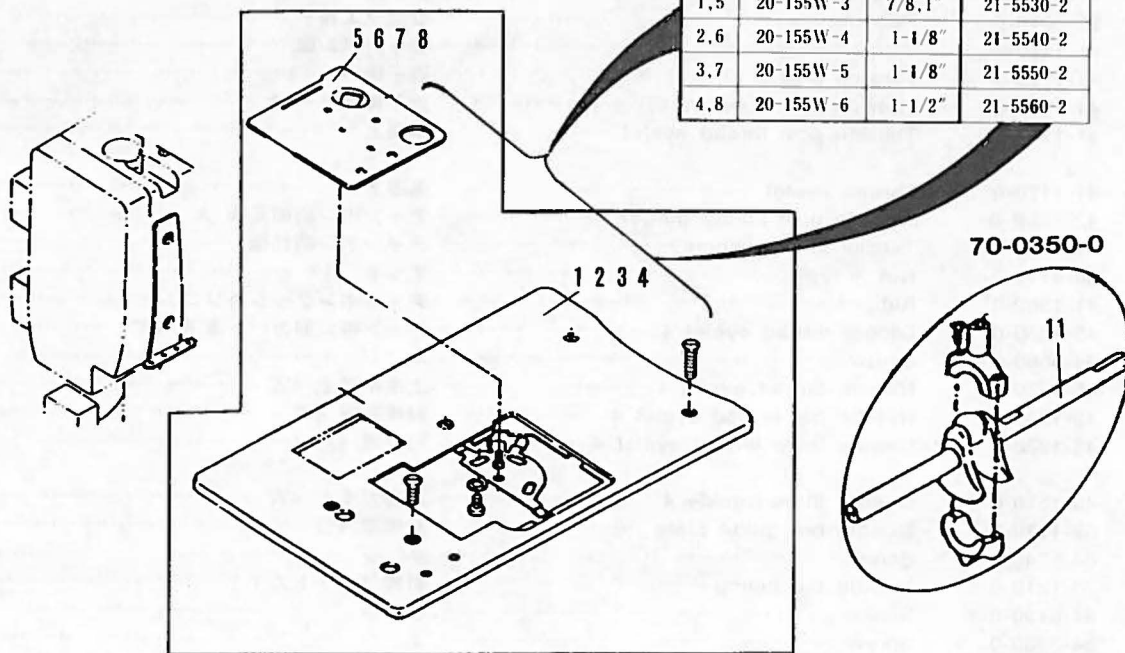

No	Set No	Gauge
14,26	10-9730-1	7/8
15,27	10-9730-2	1"
16,28	10-9730-3	1-1/8
17,29	10-9730-4	1-1/4
18,30	10-9730-5	1-1/2

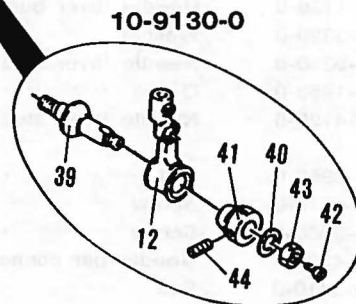

No.	Part No.	Part Name	品名	Q, ty
1	21-5530-0	Upper cloth plate (7/8",1")	ブーラー付上ベースカバー (7/8",1")	1
2	21-5540-0	Upper cloth plate (1" 1/8)	ブーラー付上ベースカバー (1" 1/8)	1
3	21-5550-0	Upper cloth plate (1" 1/4)	ブーラー付上ベースカバー (1" 1/4)	1
4	21-5560-0	Upper cloth plate (1" 1/2)	ブーラー付上ベースカバー (1" 1/2)	1
5	21-5230-0	Side plate	差板	1
6	21-5240-0	Side plate	差板	1
7	21-5250-0	Side plate	差板	1
8	21-5300-0	Side plate	差板	1
9	45-1520-0	Needle thread guide	上糸	1
11	71-8550-0	Crank shaft (5MB)	クランクシャフト 5MB	1
12	19-3130-0	Looper holder	ルーバー台	2
13	75-2470-0	Collar B	連結メガネローラー	2
14	66-5160-0	Connecting link (7/8")	ルーバー連結メガネ (7/8")	1
15	66-5170-0	Connecting link (1")	ルーバー連結メガネ (1")	1
16	66-5180-0	Connecting link (1" 1/8)	ルーバー連結メガネ (1" 1/8)	1
17	66-5190-0	Connecting link (1" 1/4)	ルーバー連結メガネ (1" 1/4)	1
18	66-5200-0	Connecting link (1" 1/2)	ルーバー連結メガネ (1" 1/2)	1
19	75-4530-0	Washer	ワッシャ	2
20	86-3120-0	Nut	ナット	2
21	19-3020-0	Looper rocker base	ルーバー元台	1
22	84-8160-0	Screw	ネジ	1
23	84-7670-0	Screw	ネジ	1
24	75-3810-0	Washer	ワッシャ	2
25	86-5020-0	Nut	ナット	2
26	66-5260-0	Connecting supporter (7/8")	ルーバー連結補助板 (7/8")	1
27	66-5270-0	Connecting supporter (1")	ルーバー連結補助板 (1")	1
28	66-5280-0	Connecting supporter (1" 1/8)	ルーバー連結補助板 (1" 1/8)	1
29	66-5290-0	Connecting supporter (1" 1/4)	ルーバー連結補助板 (1" 1/4)	1
30	66-5300-0	Connecting supporter (1" 1/2)	ルーバー連結補助板 (1" 1/2)	1
31	84-5830-0	Screw	ネジ	1
32	75-4530-0	Washer	ワッシャ	1
33	61-8130-U	Connecting rod	ルーバー連結ロッド玉	1
34	84-5670-0	Screw	ネジ	2
35	63-8120-1	Connecting ball joint	連結ロッド (左)	1
36	65-4340-1	Connecting bar	ルーバー連結棒	1
37	86-4120-0	Nut (left)	ナット (左)	1
38	86-4110-0	Nut (right)	ナット (右)	1
39	71-9010-0	Taper pin	ルーバー台テーパピン	2
40	75-4520-0	Washer	ワッシャ 中	2
41	81-4010-0	Bushing	テーパピン押しブッシュ	2
42	84-3740-0	Screw	ネジ	2
43	86-5010-0	Nut	ナット	2
44	84-5210-0	Screw	ネジ	4
45	84-6160-0	Screw	ネジ	2

19. Subclass model (サブクラス機種) Part for 1508P・PR・PD 共通

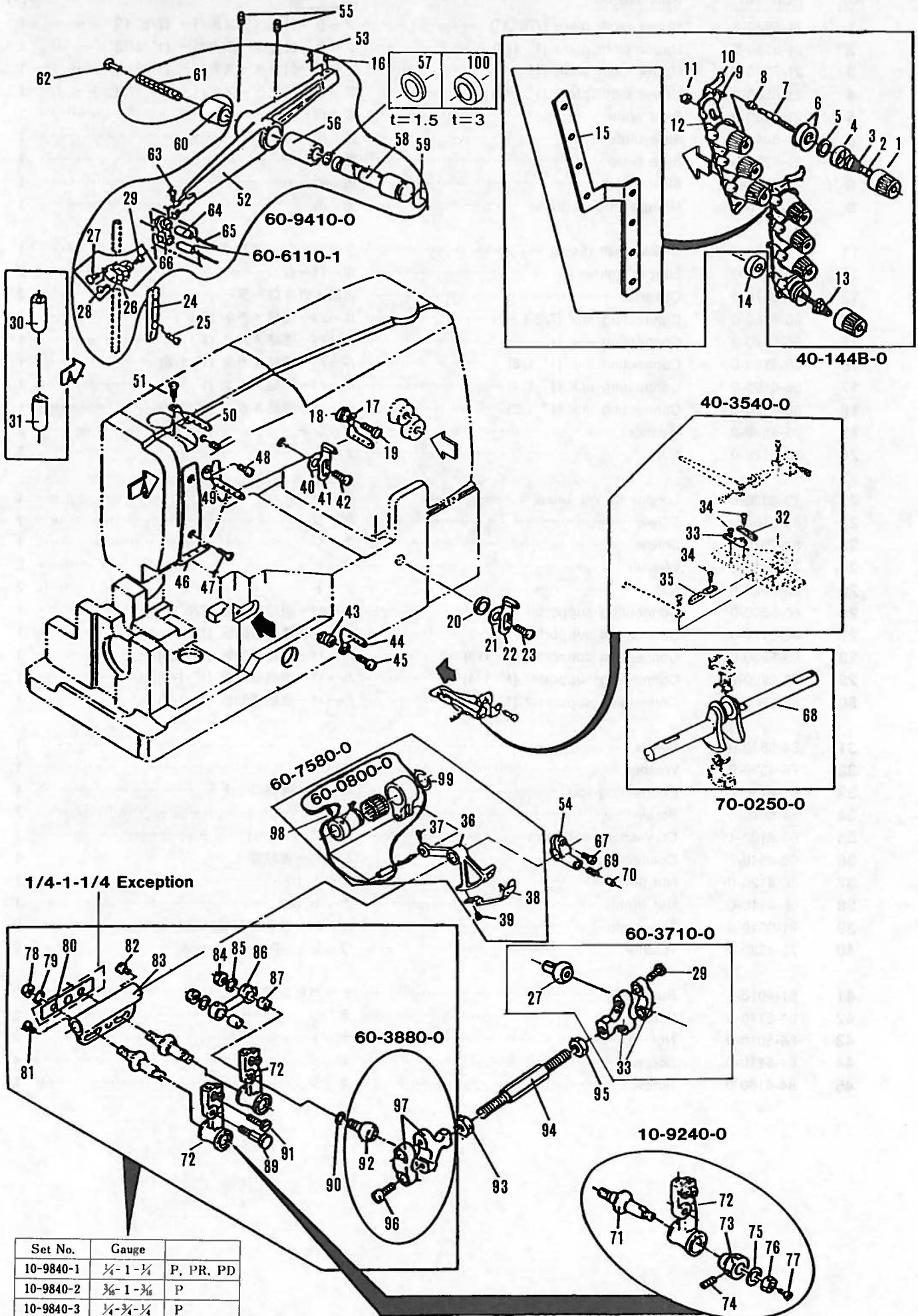

Set No.	Gauge	
10-9840-1	1/4 - 1 - 1/4	P, PR, PD
10-9840-2	3/16 - 1 - 3/16	P
10-9840-3	1/4 - 3/4 - 1/4	P

No.	Part No.	Part Name	品名	Q, ty
1	41-1010-0	Adjusting nut	チャンボン皿小ケース	8
2	41-1050-0	Adjusting ratchet	チャンボン皿ラチェット	8
3	41-7010-0	Spring (strong)	チャンボン調子バネ強	4
4	41-1070-0	Disc cover	大ケース	8
5	23-3240-0	Felt	取付フェルト	8
6	41-1110-0	Disc	チャンボン皿	16
7	41-1720-0	Tension post	調子棒中	8
8	41-1310-0	Tension post collar A	調子棒カラーA	8
9	41-1150-0	Tension post thread eyelet	糸道上	8
10	41-1170-0	Thread eyelet	糸道下	8
11	86-4110-0	Nut	連結棒用ナット右	6
12	41-113B-0	Tension post support	チャンボン調節板	1
13	41-7020-0	Spring (weak)	チャンボン調子バネ弱	4
14	41-1360-0	Rubber	チャンボンクッションゴム	1
15	41-123B-0	Tension post holder (large)	チャンボン調節元板大	1
16	85-1130-0	Screw	ネジ	1
17	47-1040-0	Looper thread eyelet 4	チャンボン皿カバー糸道4穴	1
18	75-3940-0	Washer	ワッシャ	1
19	84-5710-0	Screw	ネジ	1
20	23-1870-0	O-ring	O-リング	1
21	75-4550-0	Washer	ワッシャ	1
22	45-1030-0	Needle thread eyelet 4	上糸糸道上4穴	1
23	84-5660-0	Screw	ネジ	1
24	69-1170-0	Needle bar guide plate	針棒案内板	1
25	84-5740-0	Screw	ネジ	2
26	73-1210-1	Needle bar clamp	針棒コネクトガイド	1
27	84-6150-0	Screw	ネジ	1
28	84-3630-0	Screw	ネジ	1
29	84-3650-0	Screw	ネジ	1
30	81-1820-0	Needle bar bushing (lower)	針棒ブッシュB下	1
31	81-1810-0	Needle bar bushing (upper)	針棒ブッシュB上	1
32	47-1270-0	Looper thread guide eyelet (right)	下糸捌き糸案内(右)	1
33	47-1280-0	Looper thread guide eyelet	下糸捌き糸案内(左)	1
34	84-1610-0	Screw	ネジ	4
35	47-1210-0	Looper thread eyelet	下糸捌き板糸道	1
36	67-1330-0	Looper avoid lever	針返しレバーC	1
37	84-3660-0	Screw	ネジ	1
38	79-5080-0	Spring	押ボタン板バネ	1
39	84-1640-0	Screw	ネジ	1
40	75-4560-0	Washer	ワッシャ	1
41	45-1030-0	Needle thread eyelet 4	上糸糸道上4穴	1
42	84-5710-0	Screw	ネジ	1
43	75-3940-0	Washer	ワッシャ	1
44	47-1040-0	Looper eyelet 4	チャンボン皿カバー糸道4穴	1
45	84-5710-0	Screw	ネジ	1
46	45-1520-0	Needle thread guide 4	上糸ガイド4穴	1
47	84-4640-0	Screw	ネジ	2
48	84-3610-0	Screw	ネジ	1
49	45-1230-0	Needle thread eyelet 4	弓糸道4穴	1
50	45-1330-0	Needle bar thread eyelet 4	針棒糸道4穴	1
51	84-3610-0	Screw	ネジ	1
52	69-1050-2	Needle lever E	弓E	1
53	85-2120-0	Screw	ネジ	1
54	67-5010-1	Stop lever	ストップレバー	1
55	85-1140-0	Screw	ネジ	2
56	81-1130-0	Needle lever bushing	弓ブッシュ	1
57	75-3320-0	Washer	ワッシャt=1.5	1
58	71-9330-0	Needle lever stud	角型弓ピンC	1
59	23-1950-0	O-ring	弓ピン油止め用Oリング	1
60	81-4120-0	Needle lever stud bushing	弓ピンブッシュB	1

Subclass model (サブクラス機種) Part for 1508P·PR·PD 共通

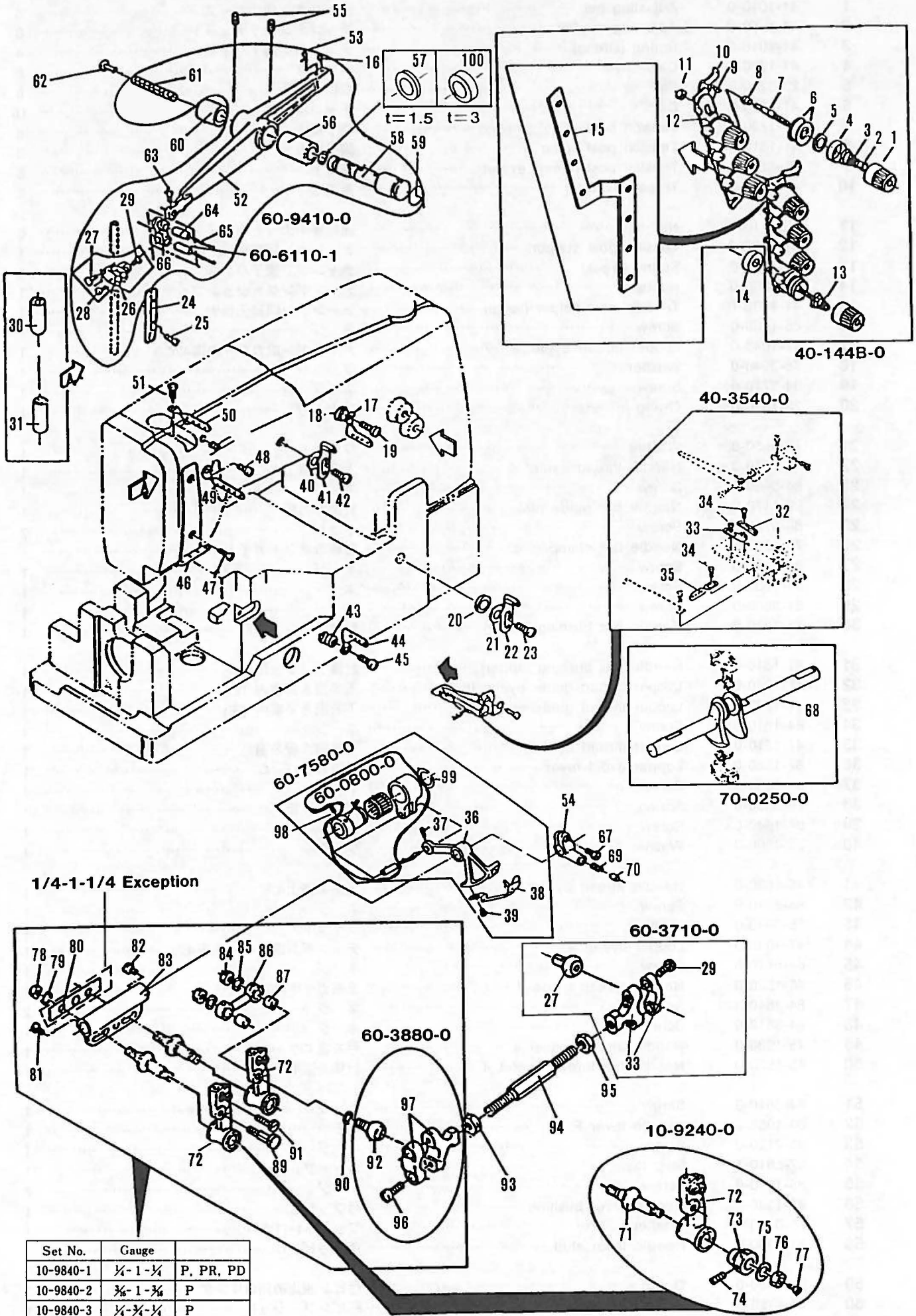

Set No.	Gauge	
10-9840-1	$\frac{1}{4}$ -1- $\frac{1}{4}$	P, PR, PD
10-9840-2	$\frac{3}{8}$ -1- $\frac{3}{8}$	P
10-9840-3	$\frac{1}{2}$ - $\frac{1}{2}$ - $\frac{1}{2}$	P

No.	Part No.	Part Name	品 名	Q, ty
61	23-3960-0	Felt	フェルト	1
62	85-1810-0	Screw	ネジ	1
63	84-3660-0	Screw	ネジ	1
64	71-4320-0	Needle bar connecting link pin	メガネヤン	2
65	23-3410-0	Felt	メガネピン用フェルト	2
66	66-1110-0	Needle bar connecting link	連結メガネ	1
67	84-8140-0	Screw	ネジ	1
68	71-8520-0	Crank shaft 5HB	クランクシャフト5HB	1
69	79-4570-0	Spring	ストップバネ	1
70	71-9510-0	Pin	ストップピン	1
71	71-9010-0	Taper pin	ルーバー台テーパピン	2
72	19-3240-0	Looper holder	ルーバー台	2
73	81-4010-1	Bushing	テーパピン押しブッシュ	2
74	84-5210-0	Screw	ネジ	4
75	75-4520-0	Washer	ワッシャ	2
76	86-5010-0	Nut	ナット	2
77	84-3740-0	Screw	ネジ	2
78	86-5020-0	Nut	ナット	2
79	75-3810-0	Washer	ワッシャ	2
80	66-5310-0	Connecting supporter (3/16-1-3/16)	ルーバー連結補助板 (3/16-1-3/16)	1
	66-5270-0	Connecting supporter (1/4-3/4-1/4)	ルーバー連結補助板 (1/4-3/4-1/4)	1
81	84-7670-0	Screw	ネジ	1
82	84-8160-0	Screw	ネジ	1
83	19-3040-0	Lopper rocker (1/4-1-1/4)	ルーバー元台 (1/4-1-1/4)	1
	19-3020-0	Lopper rocker (1/4-3/4-1/4,3/16-1-3/16)	ルーバー元台 (1/4-3/4-1/4,3/16-1-3/16)	1
84	86-3120-0	Nut	ナット	2
85	75-4530-0	Washer	ワッシャ	3
86	66-5190-0	Connecting link (1/4-1-1/4)	ルーバー連結メガネ (1/4-1-1/4)	1
	66-5210-0	Looper connecting link (3/16-1-3/16)	ルーバー連結メガネ (3/16-1-3/16)	1
	66-5170-0	Connecting link (1/4-3/4-1/4)	ルーバー連結メガネ (1/4-3/4-1/4)	1
87	75-2470-0	Connecting link roller	連結メガネローラーB	2
89	84-5830-0	Screw	ネジ	1
90	75-4530-0	Washer	ワッシャ	3
91	84-6160-0	Screw	ネジ	4
92	61-8240-U	Connecting rod (1/4-1-1/4,3/16-1-3/16)	ロッド玉 (1/4-1-1/4,3/16-1-3/16)	1
	61-8130-U	Connecting rod (1/4-4/3-4/1)	ルーバー連結ロッド玉C (1/4-3/4-1/4)	1
93	86-4120-0	Nut	ナット (左)	1
94	65-4330-1	Connecting bar	ルーバー連結棒C	1
95	86-4110-0	Nut	ナット	1
96	84-5670-0	Screw	ネジ	2
97	63-8120-1	Connecting ball joint	連結ロッド (左)	1
98	84-5210-0	Screw	ネジ	1
99	93-4060-0	Snap ring	サークリップ	1
100	75-3310-0	Washer	ワッシャt=3	1

Subclass model (サブクラス機種)

20. 1508P・PR・PD

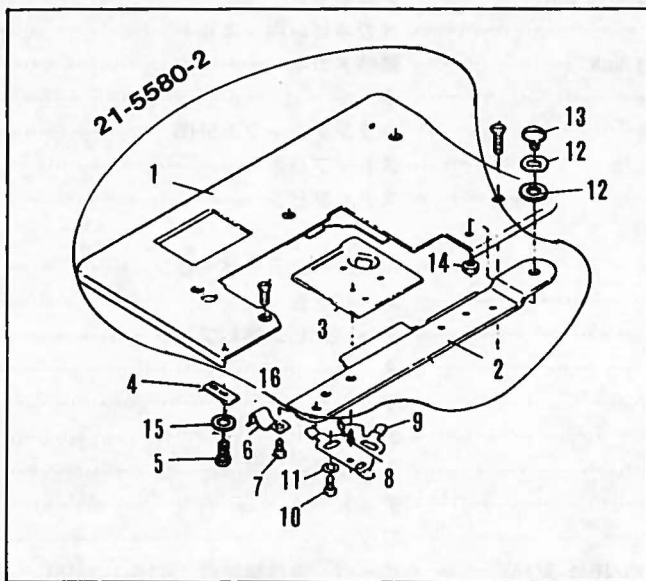

20-1550-8

1508P Type

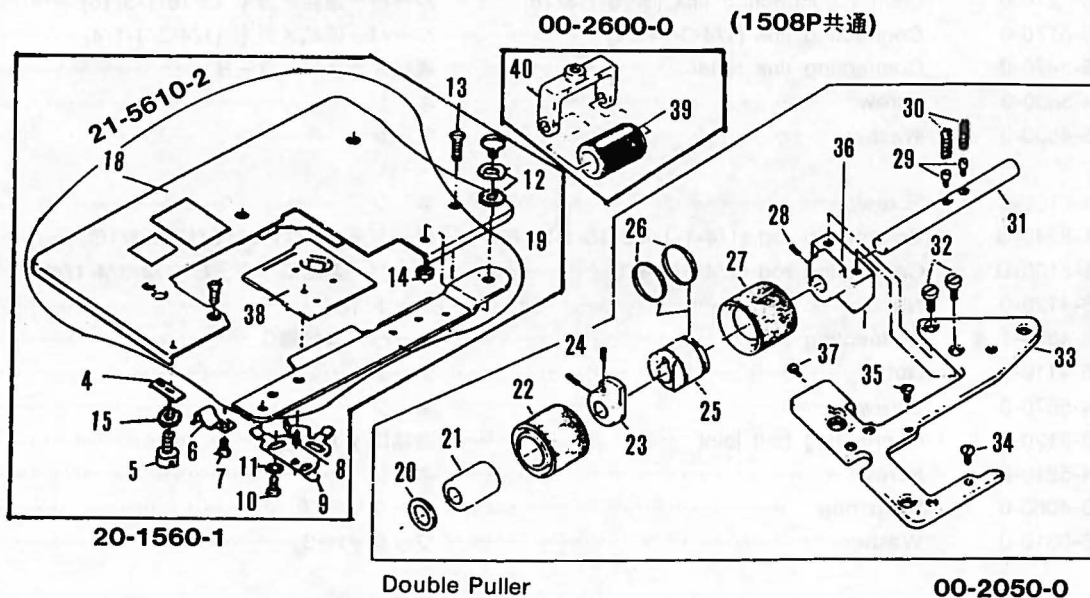

20-1560-1

Double Puller

00-2050-0

1508PD
1508PR Type

No.	Part No.	Part Name	品名	Q, ty
1	21-5580-0	Upper cloth plate	上ベースカバー1	1
2	21-5590-0	Front plate cover	前ベースカバー	1
3	21-5250-0	Slide plate	差板A	1
4	25-1710-0	Holder	前ベースカバーバネ止め板	1
5	84-3610-0	Screw	ネジ	1
6	79-5210-0	Spring	前ベースカバー板バネ	1
7	84-3640-0	Screw	ネジ	1
8	85-6110-0	Screw	ネジ	1
9	21-5320-0	Spring for slide plate	差板	1
10	84-5850-0	Screw	ネジ	3
11	75-4540-0	Washer	差板用取付ワッシャ	3
12	02-1120-0	Washer	手揚げ用バネ	2
13	85-1920-0	Screw	ネジ	1
14	86-5410-0	Nut	ナット	1
15	75-4680-0	Washer	配管取付ワッシャ	1
17	14-0910-2	Needle plate support	針板土台	1
18	21-5610-0	Upper cloth plate	上ベースカバーWP	1
19	21-5640-0	Ruller holder	前ベースカバー	1
20	75-3720-0	Washer	ルーバー台シャフトワッシャ(小)	1
21	81-5010-0	Bushing	ダブルローラーブッシュ	1
22	02-2350-0	Rear puller left	下ダブルローラー(左)	1
23	02-2320-0	Rear puller stopper left	ダブルローラー廻り止めA	1
24	84-5210-0	Screw	ネジ	2
25	02-2310-0	Rear puller stopper left	ダブルローラー廻り止めA	1
26	93-4020-0	Snap ring	ダブルローラー用後プーラーサークリップ	2
27	02-2340-0	Rear puller,right	下ダブルローラー(右)	1
28	84-5210-0	Screw	ネジ	1
29	84-1140-0	Screw	ネジ	2
30	79-4560-0	Spring	ダブルプーラー用クッションバネ	1
31	71-6530-0	Shaft	ダブルローラー用後プーラー下シャフト	1
32	84-7610-0	Screw	ネジ	2
33	14-0580-2	Needle plate support	針板土台	1
34	84-4650-0	Screw	ネジ	1
35	84-4640-0	Screw	ネジ	1
36	02-2330-0	Rear puller stopper right	下ダブルローラー(左)	1
37	84-1620-0	Screw	ネジ	1
38	21-5250-0	Side plate	差板E	1
39	02-1840-0	Rear puller vouletted roller	後プーラー上ローレットローラー	1
40	02-1510-0	Rear puller holder	後プーラー台(大)	1

Subclass model (サブクラス機種)

21. 1508PD

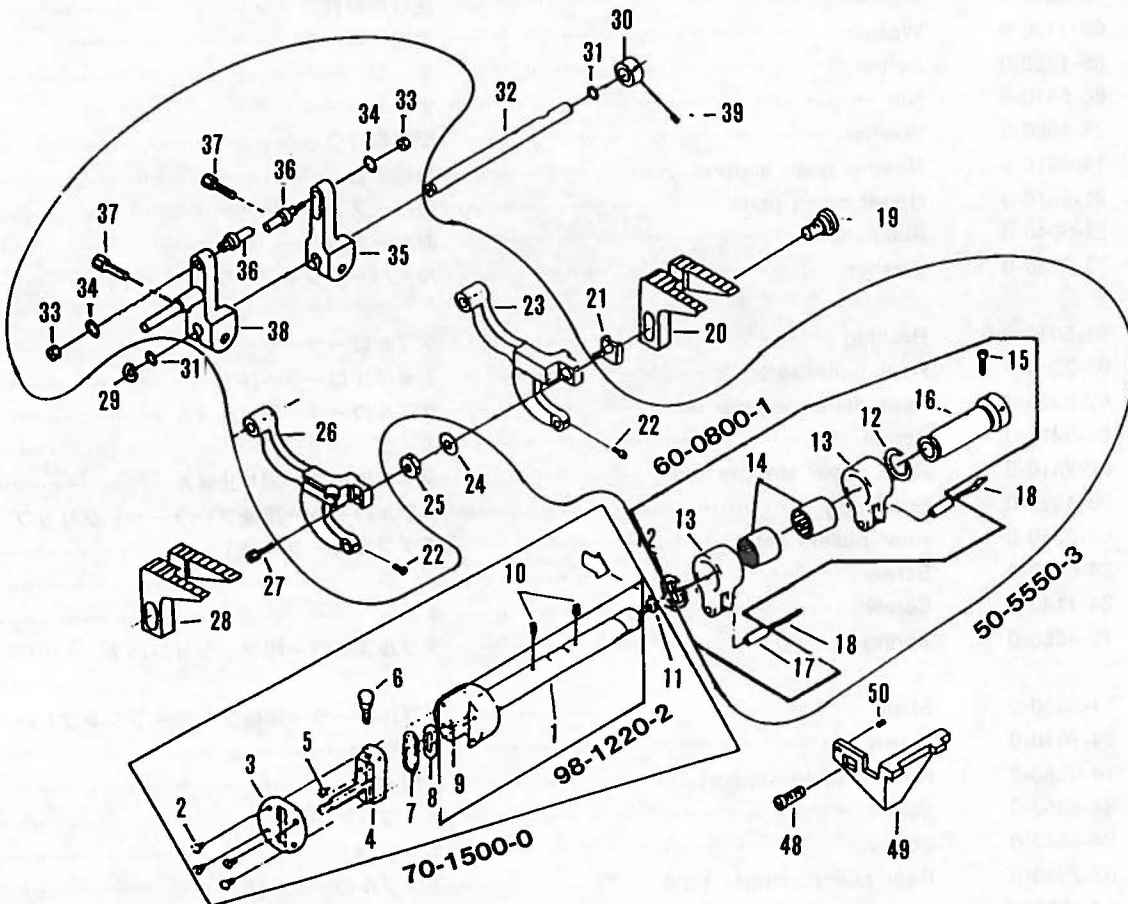

No.	Part No.	Part Name	品 名	Q, ty
1	98-1220-0	Main shaft	前下シャフト	1
2	84-6610-0	Screw	ネ ジ	4
3	51-0310-0	Head plate	メインシャフトヘッドプレート	1
4	51-0130-0	Feed crank adjusting post	送り調節芯棒C	1
5	85-6240-0	Screw	ネ ジ	1
6	84-3830-0	Screw	ネ ジ	1
7	23-1970-0	φ12.5 O-ring	φ12.5 Oリング	1
8	51-0360-0	Oil guide	送り調節芯棒オイルガード	1
9	23-3930-0	R Felt	Rフェルト	1
10	23-3410-0	Felt	メガネピン用フェルト	1
11	84-5760-0	Screw	ネ ジ	1
12	93-4060-0	φ18 Snap ring	φ18 サークリップ	2
13	63-2320-U	Eccentric B	エキセンダルマB	2
14	91-4060-0	Bearing	ベアリング	2
15	84-7150-0	Screw	ネ ジ	2
16	98-1210-0	Feed eccentric	送りエキセン玉	1
17	71-4310-0	Connecting link pin	ダルマピン	2
18	23-3410-0	Felt	メガネピン用フェルト	2
19	84-5880-0	Screw	ネ ジ	1
20	98-1190-0	Feed dog	送り歯 (右)	1
21	55-0510-0	Feed dog holder	送り歯取付台B	1
22	84-3660-0	Screw	ネ ジ	2
23	98-1170-0	Feed rocker	送り土台(右)	1
24	75-3810-0	Washer	ワッシャ	1
25	86-5010-0	Nut	ナット	1
26	98-1180-0	Feed rocker	送り土台(左)	1
27	84-6120-0	Screw	ネ ジ	1
28	98-1240-0	Feed dog	送り歯(左)	1
29	93-2610-0	"C" ring	Cリング	1
30	75-1320-1	φ10.34 Collar	φ10.34シャフトカラー	1
31	75-3720-0	Washer	ワッシャ(小)	2
32	71-6420-0	Shaft	シャフト(小)	1
33	86-4110-0	Nut	ナット	2
34	75-4530-0	Washer,small	ワッシャ(小)	2
35	98-1160-0	Feed rockar	送り土台(左)	1
36	51-2140-0	Pin	送り土台コネクトピン	2
37	85-2100-0	Screw	ネ ジ	2
38	98-1150-0	Feed rocker	送り元台(右)	1
39	84-8160-0	Screw	ネ ジ	1
48	84-3680-0	Screw	ネ ジ	1
49	98-1200-0	Needle guard	針受け	1
50	84-1130-0	Screw	ネ ジ	1

22. 1508PD Subclass model (サブクラス機種)

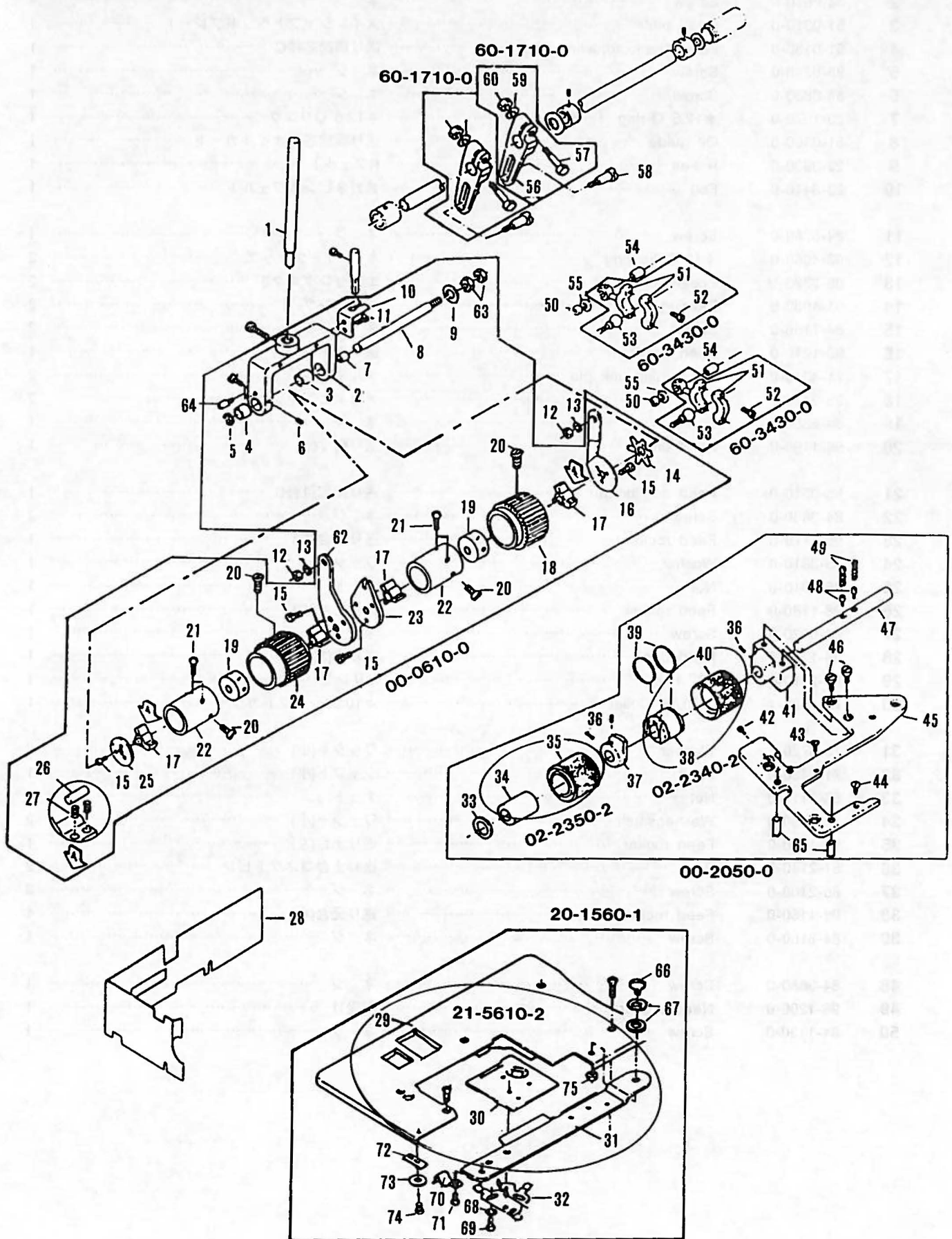

No.	Part No.	Part Name	品名	Q, ty
1	98-1110-0	Shaft	立てシャフト	1
2	98-1120-0	Puller holder	プーラー台	1
3	81-3220-0	Bushing	プーラー台シャフトブッシュ(中)	1
4	81-3210-0	Bushing,large	プーラー台シャフトブッシュ(大)	1
5	93-2210-0	φ8 Stop ring	φ8 ストップリング	1
6	84-5120-0	Screw	ネジ	1
7	81-3230-0	Puller holder shaft bushing,small	プーラー台シャフトブッシュ(小)	1
8	71-4740-0	Rear puller shaft,large	後プーラー台シャフト(大)	1
9	75-4510-0	Washer	ワッシャ	1
10	02-4590-0	Rear puller stopper	後プーラー台大用廻り止めB	1
11	84-6150-0	Screw	ネジ	2
12	86-4110-0	Nut	ナット(右)	2
13	75-5320-0	Washer B	バネ座金	2
14	79-5510-0	Puller plate spring	プーラー板バネ	1
15	84-1620-0	Screw	ネジ	12
16	02-2630-0	Rear puller connecting plate	後プーラー小用連結板	1
17	02-1010-0	Clutch A	プーラーBA	4
18	98-1130-0	Rear puller	後プーラー上(右)	1
19	02-2610-0	Rear puller thrust collar	後プーラースラスト(小)	2
20	84-4620-0	Screw	ネジ	8
21	84-7190-0	Screw	ネジ	2
22	02-2560-0	Rear puller pipe	後プーラーパイプ(小)	2
23	01-8240-0	Pin	前プーラー駆動連結ピン	1
24	98-1140-0	Rear puller	後プーラー上(左)	1
25	02-1170-0	Rear puller pipe cover	後プーラーパイプ蓋	1
26	71-4660-0	Creck clutch roller	プーラーバローラー	12
27	79-1910-0	Check clutch spring	プーラーBBバネ	24
28	98-1280-0	Side plate cover	横板カバー	1
29	21-5610-0	Upper cloth plate	上ベースカバー	1
30	21-5250-0	Slide plate E	差し板E	1
31	21-5590-0	Front plate cover	前ベースカバー	1
32	21-5320-0	Slide plate	差し板	1
33	75-3720-0	Washer	ワッシャ(小)	1
34	81-5010-0	Bushing	ダブルローラーブッシュ	1
35	02-2350-0	Rear puller left	下ダブルローラー(左)	1
36	84-5210-0	Screw	ネジ	3
37	02-2320-0	Rear puller stopper left	ダブルローラー廻り止めA	1
38	02-2310-0	Rear puller right core	ダブルローラーズライド金具	1
39	93-4020-0	Snap ring	サークリップ	2
40	02-2340-0	Rear stopper right	下ダブルローラー(右)	1
41	02-2330-0	Rear puller,right	下ダブルローラー(左)	1
42	84-1620-0	Screw	ネジ	1
43	84-4640-0	Screw	ネジ	1
44	84-4650-0	Screw	ネジ	1
45	14-0580-2	Needle plate support	針板土台	1
46	84-7610-0	Screw	ネジ	2
47	71-6530-0	Shaft	後プーラー下シャフト	1
48	84-1140-0	Screw	ネジ	2
49	79-4560-0	Spring	クッションバネ	2
50	86-3120-0	Nut	ナット	2
51	63-8100-1	Puller connecting rod	プーラー連結ロッド	2
52	84-5720-0	Screw	ネジ	4
53	61-8100-U	Connecting ball joint	プーラー連結ロッド玉	2
54	75-2470-0	Washer	ワッシャ	2
55	75-5520-0	Washer A	ワッシャA	2
56	67-1710-0	Puller driving lever,front	上シャフト連結レバー(前)	2
57	85-1910-0	Screw	ネジ	2
58	84-5840-0	Screw	ネジ	2
59	75-5520-0	Washer B	ワッシャB	2
60	86-5410-0	Nut	ナット	2
61	84-5660-0	Screw	ネジ	1
62	98-1250-0	Connecting plate	連結板	1
63	86-7610-0	Nut	ナット	2
64	84-5730-0	Screw	ネジ	1
65	71-2510-0	Pin	ピン	2
66	85-1920-0	Screw	ネジ	1
67	02-1120-0	Spring	バネ	2
68	75-4540-0	Washer	ワッシャ	3
69	84-5850-0	Screw	ネジ	3
70	79-5210-0	Spring	前ベースカバー板バネ	1
71	84-3610-0	Screw	ネジ	1
72	25-1710-0	Holder A	前ベースカバーバネ止め板A	1
73	75-4680-0	Washer	ワッシャ	1
74	84-3790-0	Screw	ネジ	1
75	86-5410-0	Nut	ナット	1

23. Thread stand (糸立て)

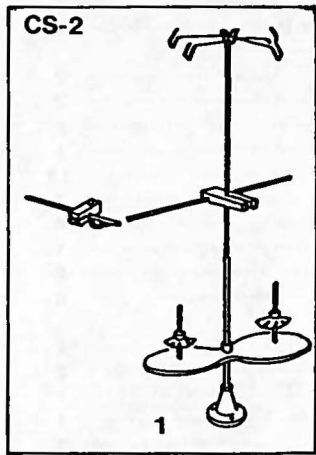

LR-1501

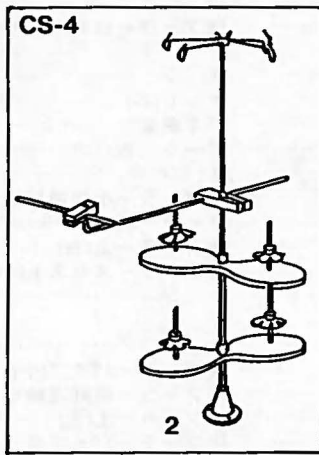

LR1502
1507

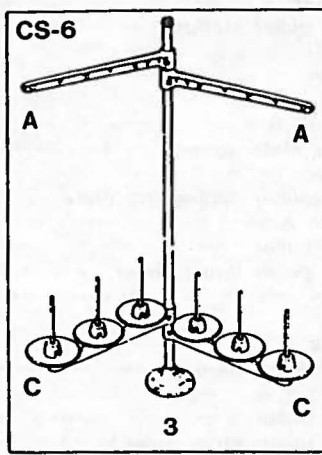

LR1503

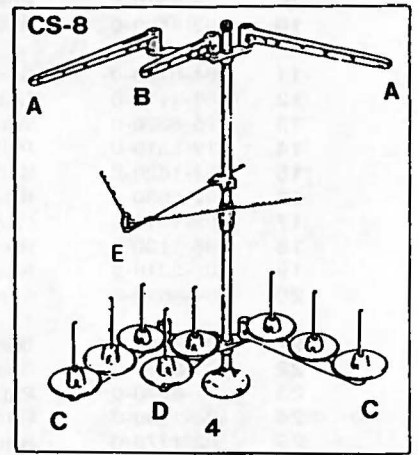

LR1504
1508

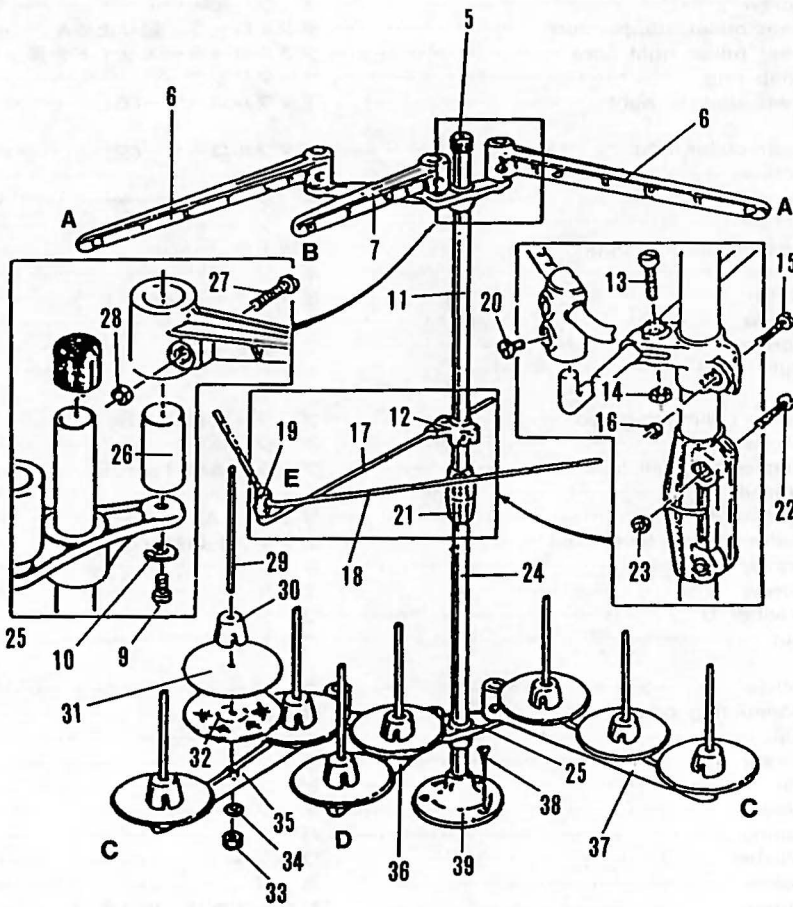

No.	Part No.	Part Name	品名	Q, ty
1	42-0020-0	Thread stand (2) CS-2	2本立て CS-2	1set
2	42-0040-0	Thread stand (4) CS-2	4本立て CS-2	1set
3	42-0060-0	Thread stand (6) CS-6	6本立て CS-6	1set
4	42-0080-0	Thread stand (8) CS-8	8本立て CS-8	1set
5	42-1200-0	Cap	キャップ	1
6	42-1160-0	Thread guide bracket (3)	糸立て台ブラケット (3)	
7	42-1170-0	Thread guide bracket (2)	糸立て台ブラケット (2)	
9	42-1350-0	Screw	ネジ	6
10	42-1360-0	Washer	ワッシャ	6
11	42-1130-0	Bar	糸立て支柱	1
12	42-1410-0	Shank	シャンク	1
13	42-1420-0	Screw	ネジ	1
14	42-1430-0	Nut	ナット	1
15	42-1440-0	Screw	ネジ	1
16	42-1450-0	Nut	ナット	1
17	42-1400-0	Thread eyelet guide arm bar	糸ガイドバー	1
18	42-1500-0	Thread eyelet guide	糸道	1
19	42-1460-0	Joint	ジョイント	1
20	42-1470-0	Screw	ネジ	2
21	42-1600-0	Joint	ジョイント	1
22	42-1610-0	Screw	ネジ	2
23	42-1620-0	Nut	ナット	2
24	42-1130-0	Bar	立て支柱	1
25	42-1310-0	Base	糸立て土台	2
26	42-1320-0	Mounting bracket	取付ブラケット	6
27	42-1330-0	Screw	ネジ	
28	42-1340-0	Nut	ナット	
29	42-1260-0	Spool pin	スプールピン	
30	42-1290-0	Spool retaining pin	糸立て固定ゴム	
31	42-1190-0	Spool mat	クッション	
32	42-1230-0	Spool tray	糸受け皿	
33	42-1270-0	Nut	ナット	
34	42-1280-0	Washer	ワッシャ	
35	42-1150-0	Spool pin bracket (3)	スプールピン土台 (3)	
36	42-1140-0	Spool pin bracket (2)	スプールピン (2)	
37	42-1150-0	Spool pin bracket (3)	スプールピン土台 (3)	
38	42-1220-0	Screw	ネジ	3
39	42-1830-0	Base	糸立て土台	1

24. Attachment·Accessories (アタッチメント・アクセサリ)

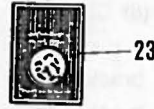
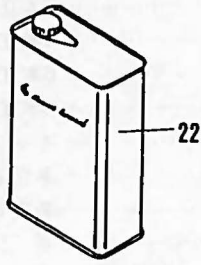
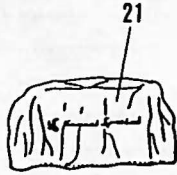
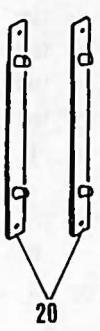

77-0060-2

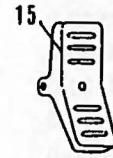
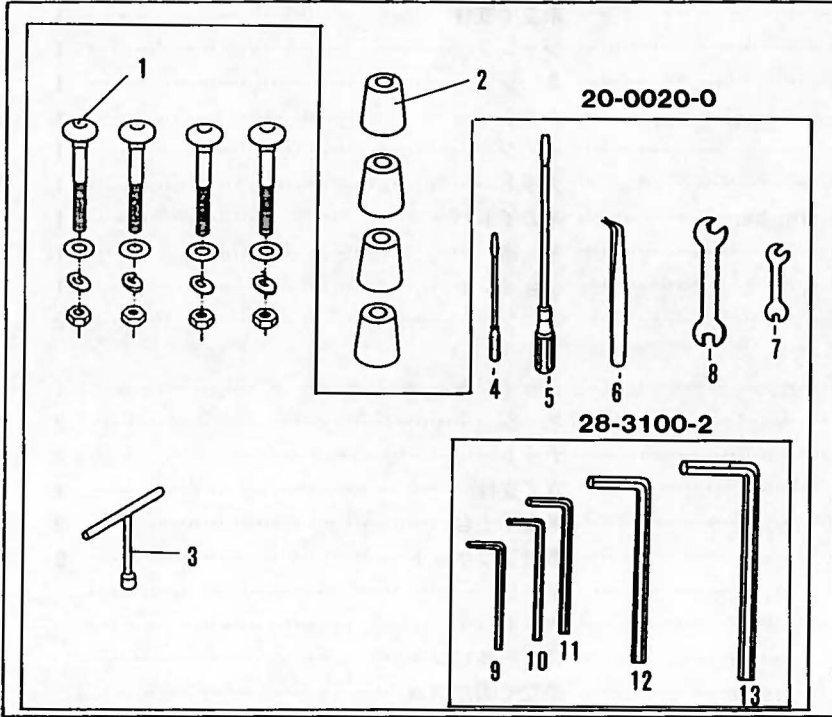
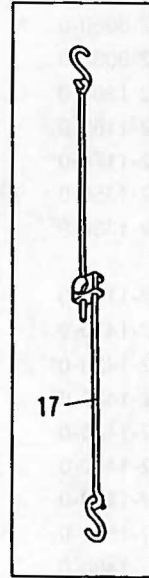

90-9000-3

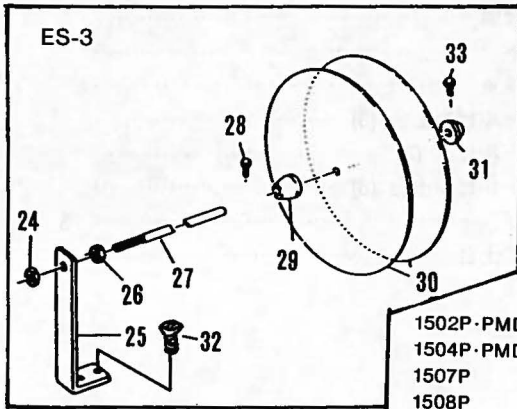

20-6030-0

1502P·PMD
1504P·PMD
1507P
1508P
1508PR
1508PD

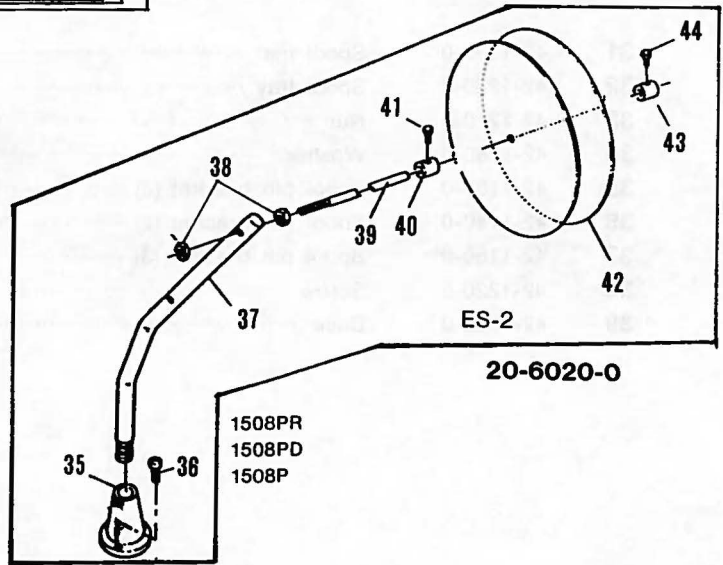

ES-2

20-6020-0

1508PR
1508PD
1508P

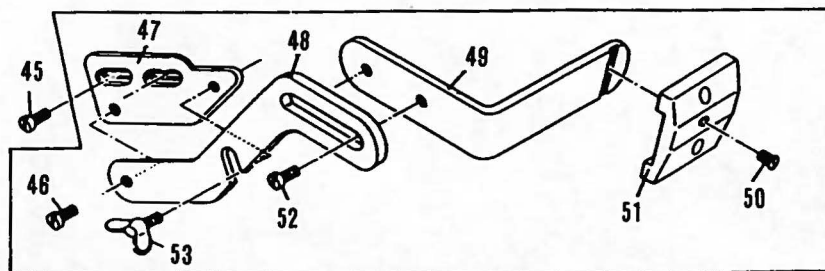

20-6400-0

Special Binder Bracket

1507P
1508P
1508PR
1508PD

No.	Part No.	Part Name	品 名	Q, ty
1	80-7510-0	Screw	クラッチモーター取付ネジM8 (ボルト)	4
2	31-1630-0	Cushion rubber	クッションゴム	4
3	28-4640-0	Wrench T (10m/m)	T型レンチ (10m/m)	1
4	28-4510-0	Screw driver (small)	ドライバー小	1
5	28-4520-0	Screw driver (large)	ドライバー大	1
6	28-0110-0	Tweezer	ピンセット	1
7	28-4210-0	Spanner (small)	スパナ小	1
8	28-4220-0	Spanner (large)	スパナ大	1
9	28-3100-0	Wrench (1.5)	六角レンチ (1.5)	1
10	28-3110-0	Wrench (2)	六角レンチ (2)	1
11	28-3120-0	Wrench (2.5)	六角レンチ (3)	1
12	28-3130-0	Wrench (3)	六角レンチ (3)	1
13	28-3140-0	Wrench (5)	六角レンチ (5)	1
15	77-0010-2	Pedal	押え揚げペダル	1
17	77-0060-2	Tie-rod (set)	連結棒 (セット)	1
20	25-1400-0	Machine mount bracket	タンク取付金具	2
21	28-0210-0	Machine cover	ミシン頭部ビニールカバー	1
22	28-6110-0	Oil TELLOSSO 33	ミシンオイル33	1
23	13-0140-6	Needle 1502P,1504P	針 UY-128GAS #14	10
	13-1510-5	Needle 1500PHD,1503P,1507P,1508P,PR,PD	針 TV-5 #21	10
24	88-1760-0	Nut	テープ支柱止ナットB	1
25	26-7400-0	Tape reel plate	テープクランプ	1
26	88-1760-0	Nut	テープ支柱止ナットB	1
27	26-8660-0	Post	テープ支柱C	1
28	87-1560-0	Hex bolt	六角ボルトM5	1
29	26-8680-0	Collar	円板受け金具	1
30	26-8670-0	Tape reel disc	226-円板テープガイド	2
31	26-8680-0	Collar	円板受け金具	1
32	87-9010-0	Screw	ネジ	2
33	87-1560-0	Hex bolt	六角ボルトM5	1
35	26-8760-0	Base	テープ立元台B	1
36	87-9010-0	Bolt	皿木ネジ小	3
37	26-8770-0	Post B	支柱パイプB	1
38	88-1760-0	Nut	テープ支柱止メナットB	2
39	26-8660-0	Tape reel post	テープ支柱C	1
40	26-8680-0	Collar	円板受け金具	1
41	87-1560-0	Hex bolt	六角ボルトM5	1
42	26-8670-0	Tape reel disc	226-円板テープガイド	2
43	26-8680-0	Collar	円板受け金具	1
44	87-1560-0	Hex bolt	六角ボルトM5	1
45	84-5710-0	Screw	ネジ	2
46	84-5660-0	Screw	ネジ	1
47	26-7310-0	Mounting base for holder	ラッパ取付元台	1
48	26-7320-0	Mounting side for holder	ラッパ取付スライド	1
49	26-7330-0	Mounting base for holder	ラッパ取付台	1
50	84-3820-0	Screw	ネジ	1
51	28-7260-0	Fixing clamp	取付台クランプ金具	1
52	84-5710-0	Screw	ネジ	2
53	26-7360-0	Screw	ネジ	1

25. Table stand assembly diagram (テーブルスタンド据付図)

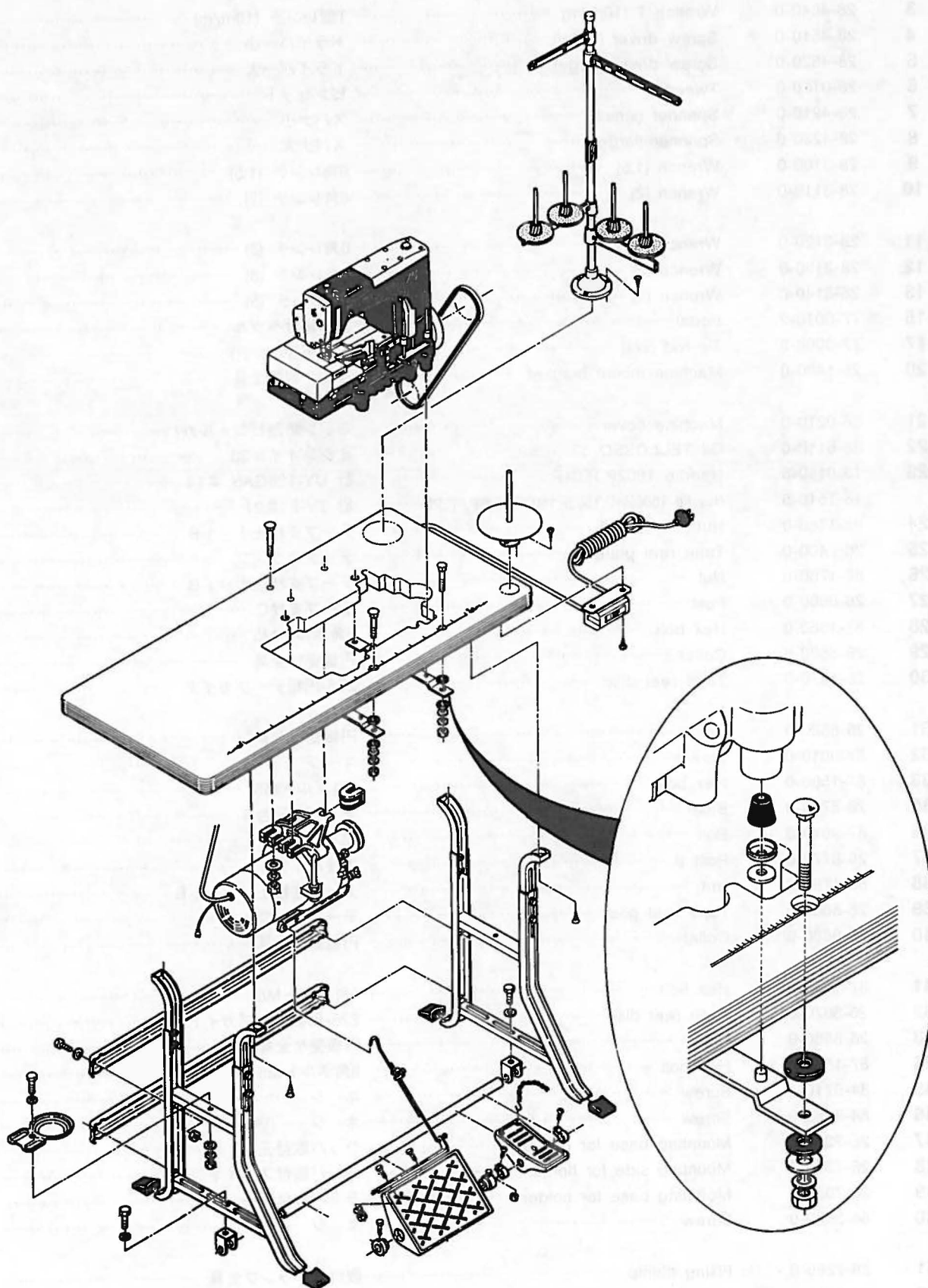

27. Index (索引)

Part No.	Q,ty	Page No.	Part No.	Q,ty	Page No.	Part No.	Q,ty	Page No.	Part No.	Q,ty	Page No.
00-0180-0		17	10-9150-1		25	15-5710-0		22	19-3180-0	1	26
-0600-0		17	-9160-0		27	-5720-0		22	-3240-0	2	36
-1610-0		41	-9160-1		22	-5730-0		22	-5110-0		22
-1150-0		17	-9180-1		22	-5740-0		22	-5120-0		22
-1400-0		23	-9180-1		25	-5810-0		22	-5130-0		22
-2000-0		17	-9240-0		33	-5820-0		22	-5180-0		22
-2050-0		37	-9240-0		35	-5830-0		22	-5210-0		22
-2050-0		41	-9730-1		22				-5220-0		22
-2280-0		17	-9730-1		31	17-4210-A		21	-5310-0		22
-2600-0		17	-9730-2		22	-4210-C		21	-5350-0		22
-2600-0		37	-9730-2		31	-4210-E		21	-5350-0		22
			-9730-3		22	-4210-G		21	-5360-0		22
01-0340-0	1	24	-9730-3		31	-4430-A		19	-5460-0		22
-1110-0	1	24	-9730-4		22	-4430-A		20	-5470-0		22
-1160-0	1	24	-9730-4		31	-4430-C		19	-5480-0		22
-1180-0	1	24	-9730-5		22	-4430-C		20	-5490-0		22
-1210-0	1	14	-9730-5		31	-5020-1		22	-5530-0		22
-1240-0	2	24	-9840-1		22	-5020-B		19	-5540-0		22
-1310-0	1	24	-9840-1		33	-5110-1		22	-5550-0		22
-1360-0	2	24	-9840-1		35	-5110-B		19	-5710-0		22
-1380-0	2	24	-9840-2		22	-5120-1		22	-5720-0		22
-1410-0	1	24	-9840-2		33	-5120-B		19	-5810-0		22
-1430-0	1	24	-9840-2		35	-5130-1		22	-5820-0		22
-1450-0	1	24	-9840-3		33	-5130-B		19	-9580-0		22
-1460-0	1	24	-9840-3		35	-5220-1		22	-9900-0		22
-1470-0	1	24				-5220-A		20	-9910-0		22
-1520-0	1	24	11-4010-0		22	-5220-B		20	-9920-0		22
-8240-0	1	42	-4020-0		22	-5320-1		22			
			-5010-0		22	-5320-B		20	20-0020-0		45
02-1010-0	2	18	-5030-0		22	-5410-1		22	-1550-1		1
-1010-0	2	24	-5040-0		22	-5420-1		22	-1550-3		29
-1010-0	4	42	-7040-0		22	-5530-1		22	-1550-4		29
-1110-0	1	18				-5530-A		20	-1550-8		37
-1120-0	1	18	12-5110-1		22	-5530-B		20	-155W-3		31
-1120-0	2	38	-5120-1		22	-5530-C		20	-155W-4		31
-1120-0	2	42	-5130-1		22	-5530-D		20	-155W-5		31
-1150-0	1	18	-5220-1		22	-5530-E		20	-155W-6		31
-1160-0	1	18	-5410-1		22	-5530-F		20	-1560-1		37
-1170-0	1	18	-5420-1		22	-5530-G		20	-1560-1		41
-1170-0	1	42	-5530-1		22	-5530-H		20	-2080-0		1
-1510-0	1	18	-5540-1		22	-5530-I		20	-3160-0		1
-1510-0	1	38	-5700-1		22	-5530-J		20	-6020-0		45
-1560-0	1	18	-5710-1		22	-5530-K		20	-6030-0		45
-1610-0	1	18	-5720-1		22	-5540-1		22	-6400-0		45
-1660-0	1	18	-5730-1		22	-5540-E		20	-6410-0		23
-1750-0	1	18	-5740-1		22	-5700-1		22			
-1780-0	1	18	-5810-1		22	-5700-A		21	21-1220-0	1	2
-1810-2	1	18	-5820-1		22	-5700-C		21	-1350-0	1	2
-1840-0	1	18	-5830-1		22	-5700-D		21	-2080-0	1	2
-1840-0	1	38				-5710-1		22	-3160-0	1	2
-1970-2	1	18	13-0140-6	10	46	-5720-1		22	-3660-0	1	2
-2080-0	1	18	-1510-5	10	46	-5730-1		22	-4020-0	1	2
-2310-0	1	38				-5740-1		22	-5190-0	1	2
-2310-0	1	42	14-0580-2	1	2	-5810-1		22	-5220-0	1	2
-2320-0	1	38	-0580-2	1	38	-5810-D		21	-5230-0	1	30
-2320-0	1	42	-0580-2	1	42	-5810-F		21	-5230-0	1	32
-2330-0	1	38	-0910-2	1	2	-5810-D		21	-5240-0	1	30
-2330-0	1	42	-0910-2	1	38	-5820-1		22	-5240-0	1	32
-2340-0	1	38	-0920-2	1	2	-5830-1		22	-5250-0	1	32
-2340-0	1	42	-5020-0		22				-5250-0	1	38
-2340-2	1	41	-5110-0		22	18-5010-0		22	-5250-0	1	38
-2350-0	1	38	-5120-0		22	-5200-0		22	-5250-0	1	42
-2350-0	1	42	-5130-0		22	-5210-0		22	-5300-0	1	32
-2350-2	1	41	-5220-0		22	-5220-0		22	-5310-0	1	2
-2510-0	1	18	-5410-0		22	-5310-0		22	-5320-0	1	38
-2560-0	1	18	-5420-0		22	-5410-0		22	-5320-0	1	42
-2560-0	2	42	-5530-0		22	-5420-0		22	-5510-0	1	2
-2610-0	1	18	-5540-0		22	-5700-0		22	-5530-0	1	30
-2610-0	2	42	-5700-0		22	-5720-0		22	-5530-0	1	32
-2630-0	1	18	-5710-0		22	-5740-0		22	-5530-2		31
-2630-0	1	42	-5720-0		22	-5820-0		22	-5540-0	1	30
-2660-0	1	18	-5730-0		22	-5830-0		22	-5540-0	1	32
-2790-0	1	18	-5740-0		22	-7220-0	1	26	-5540-2		31
-2810-0	1	18	-5810-0		22	-7250-0	1	26	-5550-0	1	32
-2990-0	1	18	-5820-0		22				-5550-2		31
-3010-2	1	18	-5830-0		22	19-3020-0	1	32	-5560-0	1	32
-4590-0	1	42				-3020-0	1	36	-5560-2		31
			15-5020-0		22	-3030-0	1	26	-5580-0	1	38
10-9120-0		29	-5110-0		22	-3040-0	1	36	-5580-2		37
-9120-1		22	-5120-0		22	-3050-0	1	14	-5590-0	1	38
-9130-0		31	-5130-0		22	-3050-0	1	26	-5590-0	1	42
-9140-0		13	-5220-0		22	-3120-0	1	30	-5610-0	1	38
-9140-1		13	-5410-0		22	-3130-0	2	32	-5610-0	1	42
-9140-1		22	-5420-0		22	-3140-0	1	14	-5610-2		37
-9150-0		25	-5530-0		22	-3150-0	1	26	-5610-2		41
-9150-1		22	-5700-0		22	-3160-0	1	28	-5640-0	1	38

From the library of: Diamond Needle Corp

Part No.	Q,ty	Page No.	Part No.	Q,ty	Page No.	Part No.	Q,ty	Page No.	Part No.	Q,ty	Page No.
21-7010-0	1	2	28-6110-0	1	46	41-1150-0	8	30	45-1210-0	1	4
-7110-0	1	2	-7260-0	1	46	-1150-0	8	34	-1220-0	1	28
			-8100-2		45	-1170-0	2	26	-1230-0	1	30
23-1200-0	4	2				-1170-0	4	4	-1230-0	1	34
-1590-0	1	2	30-0150-0	1	8	-1170-0	6	28	-1290-0	1	26
-1600-0	3	8	-1110-0		5	-1170-0	8	30	-1310-0	1	4
-1610-0	1	2	-1220-0		7	-1170-0	8	34	-1320-0	1	28
-1640-0	1	8	-2030-0		7	-121B-0	1	4	-1330-0	1	30
-1640-0	1	8	-2460-0		7	-123B-0	1	28	-1330-0	1	34
-1660-0	1	6	-2570-0		7	-123B-0	1	34	-1390-0	1	26
-1870-0	1	30	-5000-0	1	8	-1310-0	2	26	-1510-0	1	26
-1870-0	1	34	-5020-0		7	-1310-0	4	4	-1510-0	1	28
-1870-0	2	4				-1310-0	6	28	-1520-0	1	30
-1890-0	1	16	31-1630-0	4	46	-1310-0	8	30	-1520-0	1	32
-1950-0	1	10	-2190-2	1	2	-1310-0	8	34	-1520-0	1	34
-1950-0	1	30	-2190-2		1	-1320-0	1	26	-1620-0	1	4
-1950-0	1	34	-2220-0	1	8	-1320-0	1	28	-1740-0		21
-1970-0	1	10	-2490-0	1	8	-133B-0	1	4	-2250-0	1	4
-1970-0	1	12	-3140-0	7	8	-1360-0	1	28			
-1970-0	1	40	-3640-0	1	8	-1360-0	1	30	47-1040-0	1	30
-1970-0	2	18	-4090-0	1	8	-1360-0	1	34	-1040-0	1	34
-2060-0	1	2	-4100-0	1	10	-1720-0	2	26	-1040-0	1	34
-2160-0	1	2	-4100-1		9	-1720-0	4	4	-1210-0	1	28
-2290-0	1	2	-4380-0	1	6	-1720-0	6	28	-1210-0	1	30
-2340-0	1	2				-1720-0	8	30	-1210-0	1	34
-2630-0	1	2	34-6160-0	2	28	-1720-0	8	34	-1270-0	1	28
-2960-0	1	6				-7010-0	1	26	-1270-0	1	30
-2960-0	1	6	35-1070-0	1	8	-7010-0	2	4	-1270-0	1	34
-3040-0	1	2	-1110-0	1	6	-7010-0	3	28	-1280-0	1	28
-3240-0	2	26	-1220-0	1	8	-7010-0	4	30	-1280-0	1	30
-3240-0	4	4	-1990-0	1	14	-7010-0	4	34	-1280-0	1	34
-3240-0	6	28	-2030-0	2	8	-7020-0	1	26	-1310-0	1	4
-3240-0	8	30	-2040-0	1	8	-7020-0	2	4	-1310-0	1	26
-3240-0	8	34	-2040-1		7	-7020-0	3	28	-1320-0	1	4
-3410-0	1	6	-2460-0	1	8	-7020-0	4	30	-1320-0	1	26
-3410-0	1	12	-2570-0	1	8	-7020-0	4	34	-1660-0	1	28
-3410-0	1	12	-3150-0	1	8				-2010-0	1	26
-3410-0	1	12	-3170-0	2	8	42-0020-0	1	44	-2040-0	1	26
-3410-0	1	12	-3180-0	1	8	-0040-0	1	44			
-3410-0	1	14	-3220-0	1	8	-0060-0	1	44	49-1390-1	1	14
-3410-0	1	40	-3430-0	1	8	-0080-0	1	44			
-3410-0	2	10	-4120-0	7	8	-1130-0	1	44	50-5540-2		29
-3410-0	2	30	-8220-0	1	8	-1130-0	1	44	-5550-1		11
-3410-0	2	36	-9150-0	1	2	-1140-0		44	-5550-2		25
-3410-0	2	40				-1150-0		44	-5220-2		27
-3630-0	1	8	39-1080-0	1	2	-1160-0		44	-5550-3		39
-3930-0	1	12	-1330-0	1	8	-1170-0		44			
-3930-0	1	40	-1370-0	1	2	-1190-0		44	51-0130-0	1	12
-3960-0	1	10	-1670-0	1	2	-1200-0	1	44	-0130-0	1	40
-3960-0	1	30	-2160-0	1	2	-121B-0	1	26	-0310-0	1	12
-3960-0	1	36	-2330-0	1	2	-1220-0	3	44	-0310-0	1	40
-9110-0	4	8				-1230-0		44	-0360-0	1	12
-9130-0	1	2	40-111B-0		25	-123B-0	1	30	-0360-0	1	40
			-122B-0		3	-1260-0		44	-2140-0	2	40
25-1400-0	2	46	-122B-0		25	-1270-0		44			
-1710-0	1	38	-133B-0		27	-1280-0		44	55-0410-0	1	12
-1710-0	1	42	-144B-0		29	-1290-0		44	-0510-0	1	12
			-144B-0		33	-1310-0	2	44	-0510-0	1	40
26-4010-0	1	24	-144B-0		35	-1320-0	6	44	-0610-0	1	18
-4020-0	1	24	-3540-0		27	-1330-0		44	-1540-0	1	30
-4030-0	4	24	-3540-0		29	-1340-0		44	-1550-0	1	12
-4060-0	4	24	-3540-0		33	-1350-0	6	44			
-4070-0	4	24	-3540-0		35	-1360-0	6	44	60-0800-0		11
-4080-0	4	24	-3810-0		25	-1400-0	1	44	-0800-0		13
-7120-0	1	2	-3820-0		3	-1410-0	1	44	-0800-0		29
-7310-0	1	46				-1420-0	1	44	-0800-0		33
-7320-0	1	46	41-1010-0	2	26	-1430-0	1	44	-0800-0		35
-7330-0	1	46	-1010-0	4	4	-1440-0	1	44	-0800-1		39
-7360-0	1	46	-1010-0	6	28	-1450-0	1	44	-0900-0		25
-7400-0	1	46	-1010-0	8	30	-1460-0	1	44	-0900-0		27
-8660-0	1	46	-1010-0	8	34	-1470-0	2	44	-1500-0		17
-8660-0	1	46	-1050-0	2	26	-1500-0	1	44	-1500-2		17
-8670-0	2	46	-1050-0	4	4	-1600-0	1	44	-1710-0		17
-8670-0	2	46	-1050-0	6	28	-1610-0	2	44	-1710-0		41
-8680-0	1	46	-1050-0	8	30	-1620-0	2	44	-1720-0		17
-8680-0	1	46	-1050-0	8	34	-1830-0	1	44	-2160-0		9
-8680-0	1	46	-1070-0	2	26				-3430-0		17
-8680-0	1	46	-1070-0	4	4	43-1050-0	1	4	-3430-0		41
-8760-0	1	46	-1070-0	6	28	-3310-0	1	4	-3550-0		9
-8770-0	1	46	-1070-0	8	30	-3310-0	1	26	-3550-1		9
			-1070-0	8	34	-3350-0	1	4	-3700-0		9
28-0110-0	1	46	-1110-0	4	26	-3350-0	1	26	-3710-0		31
-0210-0	1	46	-1110-0	8	4	-3440-0	1	4	-3710-0		33
-3100-0	1	46	-1110-0	12	28	-3440-0	1	26	-3710-0		35
-3110-0	1	46	-1110-0	16	30				-3720-0		13
-3120-0	1	46	-1110-0	16	34	45-1010-0	2	4	-3730-0		13
-3130-0	1	46	-113B-0	1	26	-1020-0	1	4	-3740-0		17
-3140-0	1	46	-113B-0	1	28	-1020-0	3	28	-3740-0		17
-4210-0	1	46	-113B-0	1	30	-1030-0	1	30	-3860-0		23
-4220-0	1	46	-113B-0	1	34	-1030-0	1	34	-3870-0		31
-4510-0	1	46	-1150-0	2	26	-1030-0	1	34	-3880-0		33
-4520-0	1	46	-1150-0	4	4	-1030-0	2	30	-3880-0		35
-4640-0	1	46	-1150-0	6	28	-1090-0	1	26	-6110-1		9

Part No.	Q,ty	Page No.	Part No.	Q,ty	Page No.	Part No.	Q,ty	Page No.	Part No.	Q,ty	Page No.
60-6110-1		29	67-1710-0	1	18	75-1130-1	2	18	77-1140-0	1	16
-6110-1		33	-1710-0	2	42	-1140-1	1	14	-1160-0	1	16
-6110-1		35	-1720-0	1	18	-1320-1	1	12	-1210-0	1	16
-7120-0		11	-1810-0	1	24	-1320-1	1	40	-1310-0	1	16
-7120-0		11	-2220-1	1	14	-1390-1	1	14	-1330-0	1	16
-7120-1		11	-3110-1	1	12	-1390-1		13	-8110-0	1	16
-7120-2		11	-5010-1	1	34	-1540-1	1	16			
-7220-2		13				-2110-0	1	18	79-1210-0	1	16
-7580-0		33	69-1050-2	1	10	-2430-0	1	12	-1260-0	1	18
-7580-0		35	-1050-2	1	30	-2470-0	1	18	-1710-0	1	24
-7800-0		13	-1050-2	1	34	-2470-0	2	32	-1910-0	12	18
-7900-0		25	-1170-0	1	10	-2470-0	2	36	-1910-0	12	24
-7900-0		27	-1170-0	1	30	-2470-0	2	42	-1910-0	24	42
-9410-0		29	-1170-0	1	34	-3220-0	1	10	-1940-0	1	24
-9410-0		33	-1210-0	1	10	-3270-0	1	10	-2810-0		19
-9410-0		35	-1210-0	1	10	-3310-0	1	10	-2810-0		20
-9710-0		9	-2160-0	1	10	-3310-0	1	36	-2820-0		21
			-3050-2	1	10	-3320-0	1	10	-4560-0	1	38
						-3320-0	1	10	-4560-0	2	42
61-2010-U	1	17				-3320-0	1	30	-4570-0	1	36
-3120-0	1	12	70-0250-0		25	-3320-0	1	34	-5080-0	1	34
-3120-0	1	14	-0250-0		27	-3320-0	2	18	-5210-0	1	38
-3220-0	1	26	-0250-0		29	-3720-0	1	12	-5210-0	1	42
-3220-0	1	30	-0250-0		33	-3720-0	1	12	-5510-0	1	18
-3220-0	2	28	-0250-0		35	-3720-0	1	14	-5510-0	1	42
-5120-1		9	-0350-0		31	-3720-0	1	14	-6010-0	1	14
-5120-U	1	10	-0450-0		9	-3720-0	1	18	7979-2220	1	16
-7110-U	1	10	-1010-0		15	-3720-0	1	38			
-7130-U	1	10	-1090-0		15	-3720-0	1	42	80-5760-1		15
-7140-U	1	17	-1140-0		15	-3720-0	2	40	-7510-0	4	46
-8100-U	1	18	-1500-0		39	-3810-0	1	12			
-8100-U	2	42	-1530-0		11	-3810-0	1	14	81-1080-0	1	6
-8130-U	1	32				-3810-0	1	24	-1090-0	1	6
-8130-U	1	36	71-1910-0	2	4	-3810-0	1	26	-1130-0	1	10
-8210-U	1	24	-1910-0	2	26	-3810-0	1	40	-1130-0	1	34
-8230-U	1	14	-2010-0	1	14	-3810-0	2	32	-1130-0	1	6
-8230-U	1	14	-2160-0	1	26	-3810-0	2	36	-1140-0	1	6
-8230-U	1	26	-2270-0	1	24	-3940-0	1	34	-1250-0	2	24
-8240-U	1	36	-2510-0	2	42	-3940-0	1	34	-1330-0	1	6
			-2510-0	4	2	-4010-0	1	14	-1530-0	1	6
63-2010-U	1	17	-3220-0	1	14	-4460-0	1	24	-1810-0	1	34
-2320-0	1	14	-3610-0	2	24	-4510-0	1	18	-1820-0	1	30
-2320-U	1	12	-3640-0	1	24	-4510-0	1	24	-1820-0	1	30
-2320-U	2	40	-4310-0	1	12	-4510-0	1	42	-1820-0	1	34
-3210-1	1	26	-4310-0	1	14	-4520-0	1	14	-1830-0	1	6
-3530-2	1	12	-4310-0	2	40	-4520-0	2	2	-1840-0	1	6
-5110-1	1	10	-4320-0	1	12	-4520-0	2	24	-2360-0	1	6
-6210-1	1	10	-4320-0	1	12	-4520-0	2	32	-2370-0	1	6
-6210-1	1	30	-4320-0	2	10	-4520-0	2	36	-2550-0	1	6
-7110-0	1	17	-4320-0	2	30	-4530-0	1	12	-3210-0	1	18
-7130-1	1	10	-4320-0	2	36	-4530-0	1	14	-3210-0	1	42
-8100-1	1	18	-4540-0	1	14	-4530-0	1	16	-3220-0	1	18
-8100-1	2	42	-4660-0	6	18	-4530-0	1	26	-3220-0	1	42
-8120-0	1	14	-4660-0	6	24	-4530-0	1	32	-3230-0	1	18
-8120-1	1	26	-4660-0	12	42	-4530-0	2	32	-3230-0	1	42
-8120-1	1	32	-4710-0	1	18	-4530-0	2	40	-4010-0	2	32
-8120-1	1	36	-4720-0	1	18	-4530-0	3	36	-4010-1	1	14
-8210-1	1	24	-4740-0	1	42	-4530-0	3	36	-4010-1	2	36
-8210-U	1	14	-5240-0	1	24	-4540-0	3	2	-4120-0	1	10
			-5310-0	1	12	-4540-0	3	38	-4120-0	1	30
65-3020-0	1	10	-5420-0	1	16	-4550-0	1	4	-4120-0	1	34
-3020-0	1	17	-5610-0	1	14	-4550-0	1	8	-5010-0	1	38
-3020-1		9	-6120-0	1	10	-4550-0	1	30	-5010-0	1	42
-3020-1		17	-6370-0	1	18	-4550-0	1	34	-7140-0	1	6
-3340-1	1	24	-6420-0	1	12	-4550-0	2	2	-7200-0	1	6
-3340-1		23	-6420-0	1	40	-4560-0	1	4	-7350-0	2	6
-4010-0	1	14	-6510-0	1	18	-4560-0	1	4	-7530-0	2	6
-4010-1		13	-6530-0	1	38	-4560-0	1	34	-8070-0	1	6
-4330-1	1	36	-6530-0	1	42	-4670-0	3	2			
-4340-1	1	32	-6910-0	1	18	-4680-0	1	38	84-1130-0	1	40
-9020-0	1	14	-7530-0	1	12	-4680-0	1	42	-1130-0		19
			-7530-2		11	-4700-0	3	8	-1130-0		20
66-1110-0	1	10	-8520-0	1	26	-4700-0	1	8	-1130-0		21
-1110-0	1	36	-8520-0	1	28	-4910-0	1	17	-1140-0	2	38
-1310-0	1	12	-8520-0	1	30	-5320-0	2	42	-1140-0	2	42
-5160-0	1	32	-8520-0	1	36	-5340-0	1	14	-1140-0		21
-5170-0	1	32	-8550-0	1	32	-5340-0	1	18	-1190-0	2	24
-5170-0	1	32	-8580-0	1	10	-5520-0	1	18	-1610-0	1	2
-5170-0	1	36	-9010-0	1	14	-5520-0	1	18	-1610-0	3	26
-5180-0	1	32	-9010-0	2	32	-5520-0	2	42	-1610-0	3	30
-5190-0	1	32	-9010-0	2	36	-5520-0	2	42	-1610-0	4	4
-5190-0	1	36	-9210-0	1	18	-5520-0	3	17	-1610-0	4	28
-5200-0	1	32	-9330-0	1	10				-1610-0	4	34
-5210-0	1	36	-9330-0	1	30	77-0010-2	1	46	-1620-0	1	26
-5260-0	1	32	-9330-0	1	34	-0060-2	1	46	-1620-0	1	38
-5270-0	1	32	-9330-0	1	36	-0060-2		45	-1620-0	1	42
-5270-0	1	36	-9510-0	1	36	-0350-0	1	16	-1620-0	2	24
-5280-0	1	32				-0360-0	1	16	-1620-0	3	24
-5290-0	1	32	73-1130-1	1	10	-1010-0	1	16	-1620-0	3	24
-5300-0	1	32	-1210-1	1	30	-1030-0		15	-1620-0	6	18
-5310-0	1	36	-1210-1	1	30	-1070-0	1	16	-1620-0	12	42
			-1210-1	1	34	-1090-0	1	16	-1620-0		21
67-1320-1	1	14	75-1070-1	1	10	-1110-0	1	16	-1640-0	1	2
-1330-0	1	34	-1120-1	1	10						

Part No.	Q.ty	Page No.	Part No.	Q.ty	Page No.	Part No.	Q.ty	Page No.	Part No.	Q.ty	Page No.
84-1640-0	1	14	84-5620-0	1	16	84-7180-0	2	10	86-5010-0	1	6
-1640-0	1	34	-5630-0	1	16	-7180-0	2	24	-5010-0	1	12
-1670-0		20	-5630-0	2	10	-7180-0	4	18	-5010-0	1	14
-1760-0	1	12	-5640-0	1	10	-7190-0	1	18	-5010-0	1	24
-1770-0	1	12	-5640-0	4	16	-7190-0	2	42	-5010-0	1	40
-3110-0		19	-5660-0	1	4	-7610-0	2	38	-5010-0	2	17
-3110-0		20	-5660-0	1	18	-7610-0	2	42	-5010-0	2	32
-3140-0	5	24	-5660-0	1	30	-7610-0	3	2	-5010-0	2	36
-3140-0		20	-5660-0	1	34	-7620-0	2	17	-5020-0	1	14
-3140-0		21	-5660-0	1	42	-7630-0	4	2	-5020-0	1	26
-3610-0	1	2	-5660-0	1	46	-7640-0	1	16	-5020-0	2	32
-3610-0	1	4	-5660-0	2	8	-7640-0	1	26	-5020-0	2	36
-3610-0	1	4	-5660-0	2	16	-7640-0	1	28	-5410-0	1	18
-3610-0	1	8	-5660-0	2	24	-7660-0	1	14	-5410-0	1	38
-3610-0	1	14	-5660-0	3	10	-7660-0	1	26	-5410-0	1	42
-3610-0	1	34	-5660-0	5	2	-7670-0	1	14	-5410-0	2	42
-3610-0	1	34	-5660-0	6	2	-7670-0	1	26	-7410-0	1	10
-3610-0	1	38	-5670-0	2	10	-7670-0	1	32	-7410-0	1	17
-3610-0	1	42	-5670-0	2	17	-7670-0	1	36	-7420-0	1	10
-3610-0	2	4	-5670-0	2	24	-8120-0	1	16	-7420-0	1	17
-3610-0	2	24	-5670-0	2	32	-8130-0	2	24	-7610-0	1	8
-3610-0		21	-5670-0	2	36	-8140-0	1	18	-7610-0	2	18
-3620-0	3	2	-5680-0	2	10	-8140-0	1	18	-7610-0	2	42
-3630-0	1	30	-5680-0	2	10	-8140-0	1	36	-8510-0	1	16
-3630-0	1	34	-5680-0	2	26	-8160-0	1	12			
-3630-0	3	8	-5680-0	2	30	-8160-0	1	26	87-1560-0	1	46
-3640-0	1	38	-5710-0	1	2	-8160-0	1	32	-1560-0	1	46
-3640-0		21	-5710-0	1	4	-8160-0	1	36	-1560-0	1	46
-3640-0		21	-5710-0	1	4	-8160-0	1	40	-1560-0	1	46
-3650-0	1	10	-5710-0	1	28	-8610-0	2	2	-3110-0	1	2
-3650-0	1	30	-5710-0	1	30	-8620-0	3	2	-4560-0	1	24
-3650-0	1	34	-5710-0	1	34				-7510-0	1	18
-3660-0	1	10	-5710-0	1	34	85-1130-0	1	10	-9010-0	2	46
-3660-0	1	12	-5710-0	1	34	-1130-0	1	30	-9010-0	3	46
-3660-0	1	12	-5710-0	2	2	-1130-0	1	34			
-3660-0	1	12	-5710-0	2	2	-1130-0	6	10	88-1760-0	1	46
-3660-0	1	14	-5710-0	2	24	-1140-0	2	10	-1760-0	1	46
-3660-0	1	30	-5710-0	2	46	-1140-0	2	10	-1760-0	2	46
-3660-0	1	34	-5710-0	2	46	-1140-0	2	30	-4560-0	1	24
-3660-0	1	36	-5720-0	1	10	-1140-0	2	34			
-3660-0	2	40	-5720-0	1	10	-1810-0	1	10	90-9000-3		45
-3680-0	1	40	-5720-0	2	10	-1810-0	1	30			
-3680-0		19	-5720-0	2	14	-1810-0	1	36	91-2710-0	1	12
-3680-0		20	-5720-0	4	42	-1810-0	2	2	-4060-0	1	12
-3680-0		21	-5730-0	1	18	-1910-0	1	18	-4060-0	1	14
-3740-0	1	4	-5730-0	1	42	-1910-0	2	42	-4060-0	2	40
-3740-0	1	26	-5740-0	2	10	-1920-0	1	38			
-3740-0	2	32	-5740-0	2	30	-1920-0	1	42	92-2310-0	1	10
-3740-0	2	36	-5740-0	2	34	-2010-0	1	16			
-3760-0		20	-5750-0		19	-2100-0	1	14	93-2000-0	1	24
-3790-0	1	42	-5750-0		20	-2100-0	2	40	-2010-0	2	14
-3820-0	1	46	-5750-0		21	-2120-0	1	10	-2210-0	1	18
-3820-0		21	-5760-0	1	40	-2120-0	1	10	-2210-0	1	24
-3830-0	1	12	-5810-0	1	16	-2120-0	1	30	-2210-0	1	42
-3830-0	1	40	-5820-0	1	18	-2120-0	1	34	-2230-0	1	8
-3860-0		20	-5830-0	1	32	-2200-0	4	2	-2510-0	1	17
-4620-0	5	18	-5830-0	1	36	-5310-0	1	8	-2610-0	1	12
-4620-0	8	42	-5840-0	1	18	-6110-0	1	2	-2610-0	1	40
-4630-0	1	12	-5840-0	2	42	-6110-0	1	38	-4020-0	2	38
-4640-0	1	38	-5850-0	3	2	-6110-0	2	20	-4020-0	2	42
-4640-0	1	42	-5850-0	3	38	-6240-0	1	12	-4060-0	1	12
-4640-0	2	4	-5850-0	3	42	-6240-0	1	40	-4060-0	1	36
-4640-0	2	34	-5880-0	1	12	-6280-0	2	2	-4060-0	2	40
-4640-0		21	-5880-0	1	40	-6710-0	1	18	-4060-U	1	14
-4650-0	1	38	-5910-0		21	-6810-0	2	24	-6110-0	2	16
-4650-0	1	42	-6110-0	3	2	-7610-0	1	16			
-4650-0		21	-6120-0	1	14				94-2140-0	2	6
-5110-0	1	8	-6120-0	1	40	86-2110-0		19			
-5110-0	1	16	-6120-0	2	12	-2110-0		20	98-1110-0	1	42
-5110-0	2	14	-6150-0	1	18	-3110-0	2	24	-1120-0	1	42
-5110-0		21	-6150-0	1	30	-3120-0	1	18	-1130-0	1	42
-5120-0	1	42	-6150-0	1	34	-3120-0	2	32	-1140-0	1	42
-5130-0		21	-6150-0	2	18	-3120-0	2	36	-1150-0	1	40
-5210-0	1	2	-6150-0	2	42	-3120-0	2	42	-1160-0	1	40
-5210-0	1	4	-6160-0	1	14	-3140-0	1	14	-1170-0	1	40
-5210-0	1	8	-6160-0	1	26	-4110-0	1	14	-1180-0	1	40
-5210-0	1	12	-6160-0	1	26	-4110-0	1	14	-1190-0	1	40
-5210-0	1	12	-6160-0	2	32	-4110-0	1	18	-1190-0		22
-5210-0	1	18	-6160-0	3	30	-4110-0	1	26	-1200-0	1	40
-5210-0	1	26	-6160-0	4	36	-4110-0	1	32	-1200-0		22
-5210-0	1	30	-6350-0	2	14	-4110-0	1	36	-1210-0	1	40
-5210-0	1	36	-6610-0	4	12	-4110-0	2	4	-1220-0	1	40
-5210-0	1	38	-6610-0	4	40	-4110-0	2	40	-1220-2		39
-5210-0	1	28	-6610-0	8	2	-4110-0	2	42	-1230-0	1	6
-5210-0	2	12	-6640-0	8	2	-4110-0	5	28	-1240-0	1	40
-5210-0	2	14	-7110-0	2	14	-4110-0	6	30	-1240-0		22
-5210-0	2	16	-7110-0		19	-4110-0	6	34	-1250-0	1	42
-5210-0	2	38	-7120-0	1	12	-4120-0	1	12	-1280-0	1	42
-5210-0	3	42	-7120-0		19	-4120-0	1	14			
-5210-0	4	32	-7150-0	2	40	-4120-0	1	32			
-5210-0	4	36	-7150-0		21	-4120-0	1	36			
-5610-0	1	16	-7160-0		21	-4130-0	1	14			
-5610-0	1	16	-7180-0	1	18	-4130-0	1	26			

MEMO

MEMO NO.	MEMO DATE	MEMO TITLE	MEMO NO.	MEMO DATE	MEMO TITLE
1	1954.1.1	MEMO	1	1954.1.1	MEMO
2	1954.1.2	MEMO	2	1954.1.2	MEMO
3	1954.1.3	MEMO	3	1954.1.3	MEMO
4	1954.1.4	MEMO	4	1954.1.4	MEMO
5	1954.1.5	MEMO	5	1954.1.5	MEMO
6	1954.1.6	MEMO	6	1954.1.6	MEMO
7	1954.1.7	MEMO	7	1954.1.7	MEMO
8	1954.1.8	MEMO	8	1954.1.8	MEMO
9	1954.1.9	MEMO	9	1954.1.9	MEMO
10	1954.1.10	MEMO	10	1954.1.10	MEMO
11	1954.1.11	MEMO	11	1954.1.11	MEMO
12	1954.1.12	MEMO	12	1954.1.12	MEMO
13	1954.1.13	MEMO	13	1954.1.13	MEMO
14	1954.1.14	MEMO	14	1954.1.14	MEMO
15	1954.1.15	MEMO	15	1954.1.15	MEMO
16	1954.1.16	MEMO	16	1954.1.16	MEMO
17	1954.1.17	MEMO	17	1954.1.17	MEMO
18	1954.1.18	MEMO	18	1954.1.18	MEMO
19	1954.1.19	MEMO	19	1954.1.19	MEMO
20	1954.1.20	MEMO	20	1954.1.20	MEMO
21	1954.1.21	MEMO	21	1954.1.21	MEMO
22	1954.1.22	MEMO	22	1954.1.22	MEMO
23	1954.1.23	MEMO	23	1954.1.23	MEMO
24	1954.1.24	MEMO	24	1954.1.24	MEMO
25	1954.1.25	MEMO	25	1954.1.25	MEMO
26	1954.1.26	MEMO	26	1954.1.26	MEMO
27	1954.1.27	MEMO	27	1954.1.27	MEMO
28	1954.1.28	MEMO	28	1954.1.28	MEMO
29	1954.1.29	MEMO	29	1954.1.29	MEMO
30	1954.1.30	MEMO	30	1954.1.30	MEMO
31	1954.1.31	MEMO	31	1954.1.31	MEMO
32	1954.2.1	MEMO	32	1954.2.1	MEMO
33	1954.2.2	MEMO	33	1954.2.2	MEMO
34	1954.2.3	MEMO	34	1954.2.3	MEMO
35	1954.2.4	MEMO	35	1954.2.4	MEMO
36	1954.2.5	MEMO	36	1954.2.5	MEMO
37	1954.2.6	MEMO	37	1954.2.6	MEMO
38	1954.2.7	MEMO	38	1954.2.7	MEMO
39	1954.2.8	MEMO	39	1954.2.8	MEMO
40	1954.2.9	MEMO	40	1954.2.9	MEMO
41	1954.2.10	MEMO	41	1954.2.10	MEMO
42	1954.2.11	MEMO	42	1954.2.11	MEMO
43	1954.2.12	MEMO	43	1954.2.12	MEMO
44	1954.2.13	MEMO	44	1954.2.13	MEMO
45	1954.2.14	MEMO	45	1954.2.14	MEMO
46	1954.2.15	MEMO	46	1954.2.15	MEMO
47	1954.2.16	MEMO	47	1954.2.16	MEMO
48	1954.2.17	MEMO	48	1954.2.17	MEMO
49	1954.2.18	MEMO	49	1954.2.18	MEMO
50	1954.2.19	MEMO	50	1954.2.19	MEMO
51	1954.2.20	MEMO	51	1954.2.20	MEMO
52	1954.2.21	MEMO	52	1954.2.21	MEMO
53	1954.2.22	MEMO	53	1954.2.22	MEMO
54	1954.2.23	MEMO	54	1954.2.23	MEMO
55	1954.2.24	MEMO	55	1954.2.24	MEMO
56	1954.2.25	MEMO	56	1954.2.25	MEMO
57	1954.2.26	MEMO	57	1954.2.26	MEMO
58	1954.2.27	MEMO	58	1954.2.27	MEMO
59	1954.2.28	MEMO	59	1954.2.28	MEMO
60	1954.2.29	MEMO	60	1954.2.29	MEMO
61	1954.2.30	MEMO	61	1954.2.30	MEMO
62	1954.3.1	MEMO	62	1954.3.1	MEMO
63	1954.3.2	MEMO	63	1954.3.2	MEMO
64	1954.3.3	MEMO	64	1954.3.3	MEMO
65	1954.3.4	MEMO	65	1954.3.4	MEMO
66	1954.3.5	MEMO	66	1954.3.5	MEMO
67	1954.3.6	MEMO	67	1954.3.6	MEMO
68	1954.3.7	MEMO	68	1954.3.7	MEMO
69	1954.3.8	MEMO	69	1954.3.8	MEMO
70	1954.3.9	MEMO	70	1954.3.9	MEMO
71	1954.3.10	MEMO	71	1954.3.10	MEMO
72	1954.3.11	MEMO	72	1954.3.11	MEMO
73	1954.3.12	MEMO	73	1954.3.12	MEMO
74	1954.3.13	MEMO	74	1954.3.13	MEMO
75	1954.3.14	MEMO	75	1954.3.14	MEMO
76	1954.3.15	MEMO	76	1954.3.15	MEMO
77	1954.3.16	MEMO	77	1954.3.16	MEMO
78	1954.3.17	MEMO	78	1954.3.17	MEMO
79	1954.3.18	MEMO	79	1954.3.18	MEMO
80	1954.3.19	MEMO	80	1954.3.19	MEMO
81	1954.3.20	MEMO	81	1954.3.20	MEMO
82	1954.3.21	MEMO	82	1954.3.21	MEMO
83	1954.3.22	MEMO	83	1954.3.22	MEMO
84	1954.3.23	MEMO	84	1954.3.23	MEMO
85	1954.3.24	MEMO	85	1954.3.24	MEMO
86	1954.3.25	MEMO	86	1954.3.25	MEMO
87	1954.3.26	MEMO	87	1954.3.26	MEMO
88	1954.3.27	MEMO	88	1954.3.27	MEMO
89	1954.3.28	MEMO	89	1954.3.28	MEMO
90	1954.3.29	MEMO	90	1954.3.29	MEMO
91	1954.3.30	MEMO	91	1954.3.30	MEMO
92	1954.3.31	MEMO	92	1954.3.31	MEMO
93	1954.4.1	MEMO	93	1954.4.1	MEMO
94	1954.4.2	MEMO	94	1954.4.2	MEMO
95	1954.4.3	MEMO	95	1954.4.3	MEMO
96	1954.4.4	MEMO	96	1954.4.4	MEMO
97	1954.4.5	MEMO	97	1954.4.5	MEMO
98	1954.4.6	MEMO	98	1954.4.6	MEMO
99	1954.4.7	MEMO	99	1954.4.7	MEMO
100	1954.4.8	MEMO	100	1954.4.8	MEMO

From the library of: Diamond Needle Corp

MEMO

MEMO

MEMO

MEMO

 **MORIMOTO MFG. CO., LTD.**

MAIN FACTORY

180, Suna Shijohnawate-city, Osaka 575, Japan

Tel: (0720) 77-1221 Telex:-5349134 KSPCAL-J Fax: (0720) 78-9649

TOKYO OFFICE

5-16-7, Kohtobashi Sumida-ku, Tokyo 130, Japan

Tel: (03)3635-5121 Fax: (03)3635-5123

OKAYAMA OFFICE

Village Okuda 1F. 24-19, Okuda-Honmachi Okayama-city 700, Japan

Tel: (0862) 32-9120 Fax: (0862) 22-8292

KANSAI SPECIAL U.S.A. CORP.

640 Gotham Parkway Carlstadt N.J. 07072 U.S.A.

Tel: (201) 460-0350 Telex: 219449 (KSPCUR) Fax: (201) 460-1633

MORIMOTO MFG. (H.K.) LTD.

203-207 G/F, Lai Chi Kok Road, Sham Shui Po, Kowloon, Hong Kong

Tel: 3-918357-9 Telex: 31167 MORHK HX Fax: 3-7891707

MORIMOTO MFG. (H.K.) LTD. SINGAPORE REP. OFFICE

66 East Coast Road, #04-04 Grth Building Singapore 1542

Tel: 3457576 Telex: RS25138 A/B: MMSPL Fax: 3449603

KANSAI SPECIAL MI EUROPE G.M.B.H.

Wahler Strasse 37 4000 Düsseldorf, 30 W. GERMANY

Tel: 0211-658020 Telex: 8586555 KSWG D Fax: 0211-6581529